

**User Guide**

# Milliflex<sup>®</sup> Rapid System 2.0 AutoSpray Station



MilliporeSigma is the U.S. and Canada Life Science business of Merck KGaA, Darmstadt, Germany.

## Table of Contents

<b>Introduction</b>	<b>3</b>	<b>Using the AutoSpray Station</b>	<b>12</b>
The Milliflex® Rapid System 2.0 AutoSpray Station .....	3	Basic operations .....	12
ATP bioluminescence reaction chemistry .....	4	Installing the vials .....	13
<b>General Description</b>	<b>4</b>	The main functions of the AutoSpray Station .....	13
The AutoSpray Station and its accessories .....	4	Powering up the AutoSpray Station .....	14
The control panel .....	4	Using the AutoSpray Station .....	15
The rear of the AutoSpray Station .....	4	Menu function .....	28
<b>Operating Principle</b>	<b>5</b>	Verification functions .....	32
Spraying action .....	5	Decontamination function .....	35
<b>Installing the AutoSpray Station</b>	<b>6</b>	Volume Adjustment function .....	38
Unpacking .....	6	Shutdown .....	42
Precautions .....	6	<b>Maintenance</b>	<b>43</b>
Milliflex® Rapid reagent and cleaning kits .....	7	Maintenance schedule .....	43
Letting the AutoSpray Station go into sleep mode .....	7	Preventive maintenance .....	43
Installation recommendations .....	8	Replacing a nebulizer.....	46
Setting up the AutoSpray Station .....	9	Nebulizer maintenance .....	48
Preparing the AutoSpray Station for its first use .....	12	<b>Troubleshooting</b>	<b>51</b>
		<b>Spare Parts and Accessories</b>	<b>52</b>
		<b>Specifications and Operating Requirements</b>	<b>53</b>
		<b>Operator &amp; Equipment Safety Instructions</b>	<b>54</b>
		<b>Standard Product Warranty</b>	<b>54</b>
		<b>Technical Assistance</b>	<b>54</b>

## Notice

The information in this document is subject to change without notice and should not be construed as a commitment by our company. We assume no responsibility for any errors that may appear in this document. This manual is believed to be complete and accurate at the time of publication. In no event shall our company be liable for incidental or consequential damages in connection with, or arising from, the use of this manual.

# Introduction

## The Milliflex® Rapid System 2.0 AutoSpray Station

This user guide is intended to assist lab personnel in using the Milliflex® Rapid 2.0 AutoSpray Station (Cat. No. MXRP2SPRKT), a key component of the Milliflex® Rapid System 2.0. The role of the AutoSpray Station is to automatically and evenly apply the reagents for the enzymatic reaction to the membrane filter surface.

### The Milliflex® Rapid System 2.0

The Milliflex® Rapid System 2.0 is a solution for the rapid detection and quantification of viable microorganisms (bacteria, yeasts and molds) in filterable samples, allowing an earlier response to a contamination issue. Based on highly sensitive adenosine triphosphate (ATP) bioluminescence technology, it delivers faster total viable count results than traditional methods such as membrane filtration and pour plates. The Milliflex® Rapid System 2.0 is suitable for both rapid sterility and rapid bioburden testing.

The central hardware components of the Milliflex® Rapid System 2.0 are the Milliflex® Rapid System 2.0 Detection Tower (Cat. No. MXRDP2DT00), which performs automated, software-based detection, imaging, and quantification of viable microorganisms that have been grown on media plates as microcolonies, and the Milliflex® Rapid 2.0 AutoSpray Station. For an optimal workflow and fastest detection results, we strongly recommend using the Milliflex® Rapid System 2.0 together with the proven Milliflex Oasis® system for efficient membrane filtration in an isolator.

### The Milliflex® Rapid System 2.0 workflow is performed in three steps:

1. Any microorganisms contained in a liquid sample are captured on a Milliflex Oasis® membrane filter which is then transferred onto a media plate and incubated for growth.
2. After incubation, reagents are evenly distributed onto the membrane filter by the Milliflex® Rapid 2.0 Autospray Station to perform an enzymatic reaction that leads to bioluminescence where microcolonies are present.
3. The emitted light allows any microcolonies on the membrane filter to be automatically detected and counted by the Milliflex® Rapid System 2.0 Detection Tower and its software.

**Note:** For details on using the Milliflex® Rapid System 2.0 Detection Tower and the Milliflex Oasis® system, consult the respective user guides.

## ATP bioluminescence reaction chemistry

ATP, the primary energy carrier of living organisms, is present in all living cells, including bacteria, yeasts and molds. To detect the ATP present in the microorganisms that have been captured during the filtration step, the following reagents are applied to the membrane.

- Reagent #1—ATP Releasing Reagent (MXRPBLRST): acts on the microorganisms captured on the membrane surface, making the ATP from the cells available for detection by the system
- Reagent #2—Bioluminescence Reagent (MXRPBLRST): reacts with the ATP released by Reagent #1, upon which light (photons) is emitted

The chemical reaction, catalyzed by the enzyme luciferase, is an oxidation described by the equation below:

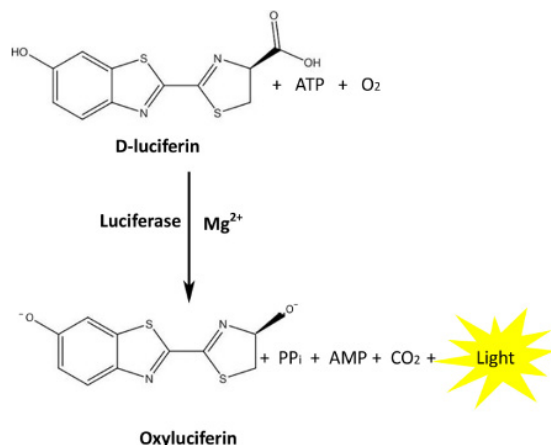

### Legend:

- D-Luciferin: Substrate
- ATP: Adenosine triphosphate
- O<sub>2</sub>: Oxygen (from atmosphere)
- Luciferase: Enzyme from a recombinant source
- Mg<sup>2+</sup>: Magnesium ions (cofactor in trace quantities)
- AMP: Adenosine monophosphate
- PP<sub>i</sub>: Pyrophosphate
- OxL: Oxyluciferin (oxidized substrate)
- CO<sub>2</sub>: Carbon dioxide

## General Description

### The AutoSpray Station and its accessories

The illustration below shows the instrument after removal of the protective front cover.

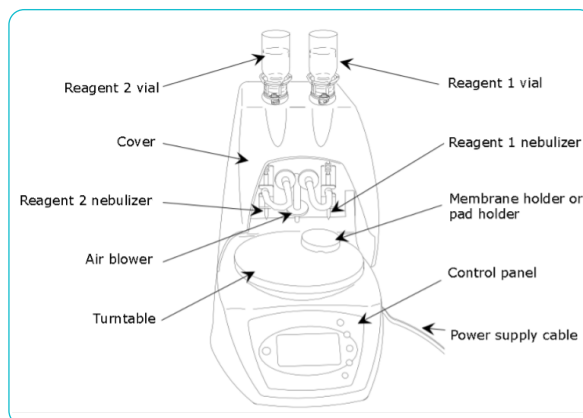

### The control panel

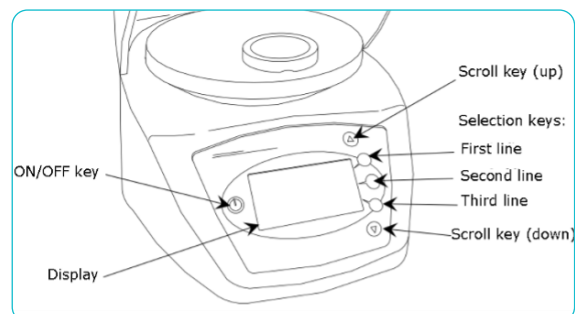

### The rear of the AutoSpray Station

The 24 VDC power input, to which the DC power unit is connected (see Installing the AutoSpray Station), is located on the left.

**Important:** The USB port (right) is only for maintenance use by authorized technicians.

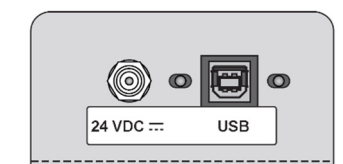

# Operating Principle

## Spraying action

The AutoSpray Station applies a very small volume (less than 2  $\mu\text{L}$  per  $\text{cm}^2$ ) of reagent evenly over the surface of a Milliflex Oasis<sup>®</sup> membrane filter utilizing the Venturi principal. It delivers the liquid reagents to a glass nebulizer through fine capillary tubing controlled by a precisely timed valve mechanism. Inside the nebulizer, air is mixed with the small volume of liquid to produce droplets that are directed onto the membrane's surface in circular motions, resulting in an even distribution of reagent over the membrane surface.

**Note:** A small light-emitting diode located behind each nebulizer is powered up during the spraying action.

## Nebulizer

The Milliflex<sup>®</sup> Rapid System 2.0 AutoSpray Station uses dedicated glass nebulizers to spray the two reagents.

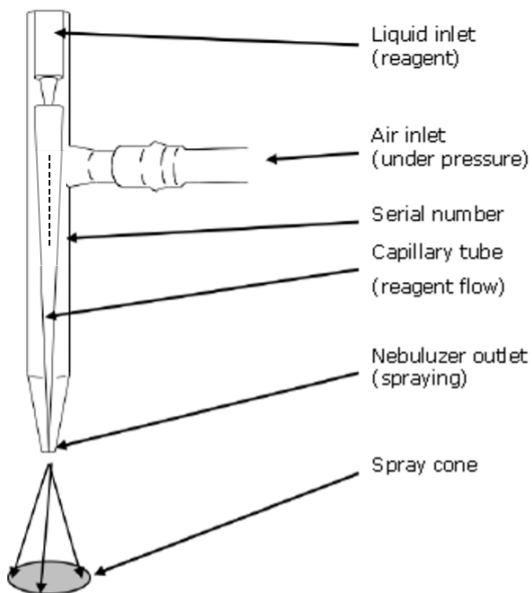

**Note:** The nebulizers are precision components that must be handled with care. Their thin capillary outlet requires proper cleaning in order to prevent clogging (see Precautions for Nebulizers).

## Pinch valves

Pinch valves located upstream of each nebulizer control the fluid circuit. During operation, they open to allow a precise volume of liquid to enter the nebulizer.

**Caution:** When the AutoSpray Station is disconnected from the power outlet or the power supply is interrupted, the pinch valves are switched off, which opens them. Any mounted vials will thus empty their contents through the nebulizer. Always remove the vials from the Luer ports when not in use.

## Sweeping motion

The reagent is sprayed over the entire surface of the membrane filter using a back-and-forth sweeping motion created by the turntable and rotation of the membrane filter holder, whereas the nebulizer does not move.

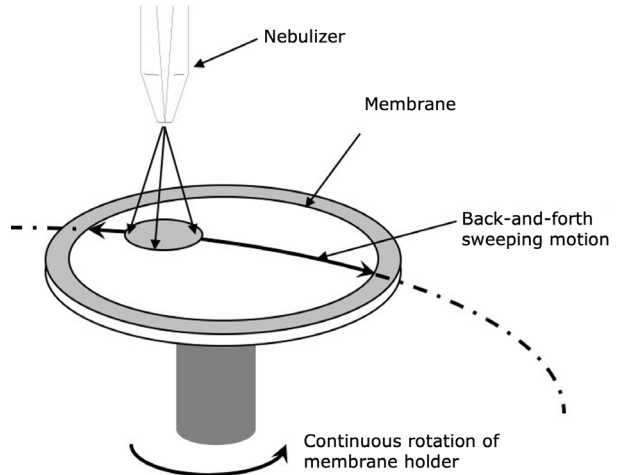

**Note:** The above illustration is not to scale.

## Reagent dispensing and drying

The Milliflex<sup>®</sup> Rapid System 2.0 AutoSpray Station is calibrated to deliver a volume of 35  $\mu\text{L} \pm 10 \mu\text{L}$  using the Autospraying, Reagent 1, and Reagent 2 functions. Turntable rotation places the inserted membrane filter holder into positions where the respective functions can be performed (see illustration below).

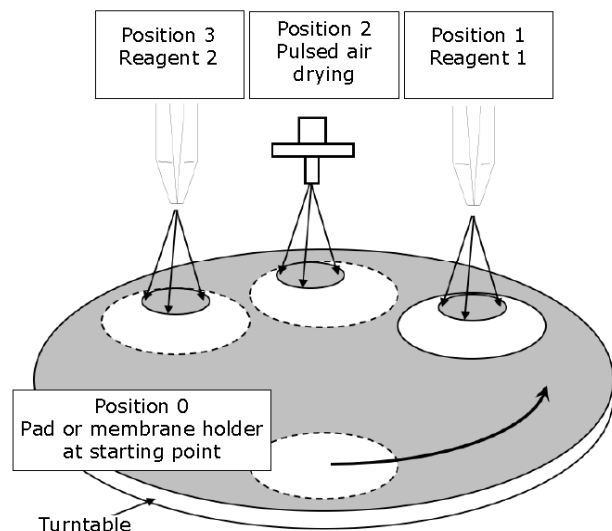

# Installing the AutoSpray Station

## Unpacking

1. Remove the following items from the packaging:

- The box of accessories
- The AutoSpray Station and its protective packaging
- The safety instructions
- The certificate of conformity

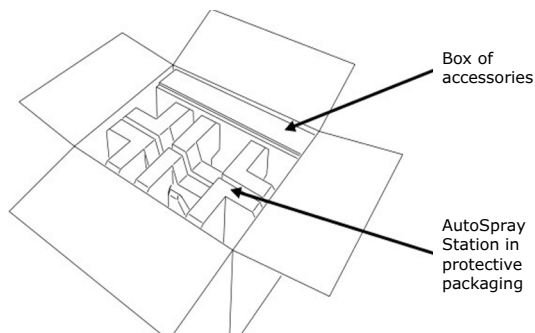

2. Remove the AutoSpray Station's protective packaging.

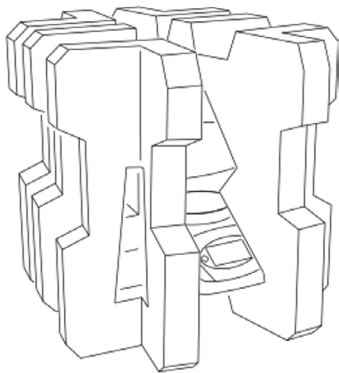

3. Open the box of accessories. It contains the following:

- One membrane holder
- One pad holder
- Three nebulizer boxes marked 1, 2, and spare
- Six Millex™-FG sterile air filters
- Four silicone liquid tubes
- One turntable
- Two stainless steel caps
- One 5 mL female Luer syringe
- One nebulizer cleaner (70-Eluo syringe)

## Precautions

**Note:** Before working with the AutoSpray Station, read Operator and Equipment Safety.

### Precautions for nebulizers

The nebulizers are precision components and must be handled with care. Their thin capillary outlet requires proper cleaning in order to prevent partial or total clogging. The following cleaning procedure must be strictly applied:

- The AutoSpray Station should be used in a laminar flow hood environment to prevent particles from entering the nebulizers.
- Clean the fluid circuit including the nebulizers at the beginning and end of each day's operations using the AutoSpray Station's Cleaning function and the Milliflex® Rapid cleaning and decontamination kit (see Spare Parts and Accessories).
- To prevent any risk of nebulizer clogging, always use a vial with a new septum (possible risk of rubber particles separating from the septum) and do not reuse the same adapter with different vials.
- Whenever the reagent or cleaning agent vials are not in use, place the stainless steel caps onto the Luer ports to prevent particles entering the unit.
- To ensure consistent reproducibility of the volume of reagent dispensed, always run a Priming cycle whenever the reagent vial is changed or the process is stopped deliberately mid-cycle.

### Precautions for silicone liquid tubes

When the AutoSpray Station is switched on, a pinch valve upstream of the nebulizer pinches the silicone liquid tubes to close the fluid circuit and prevent liquid from leaking out. The valve opens the circuit only when reagents or cleaning agents are being sprayed.

To prevent premature wear or distortion of the silicone liquid tubes, always shut down the AutoSpray Station at the end of the day's operations (see Shutdown), having first run the Cleaning procedure. Shutting down the AutoSpray Station opens the pinch valves, so never store the system with vials installed.

**Note:** When the Cleaning function is run at the point of equipment shutdown (see Shutdown), the AutoSpray Station shuts down automatically after the Cleaning cycle.

If the AutoSpray Station is not shut down, the system goes into sleep mode (see Letting the AutoSpray Station go into Sleep Mode). This opens the pinch valves to protect the silicone liquid tubes. The system goes into sleep mode when no key has been pressed for one hour after the Air steps of the Cleaning and Decontamination functions (see Precautions for Silicone Liquid Tubes).

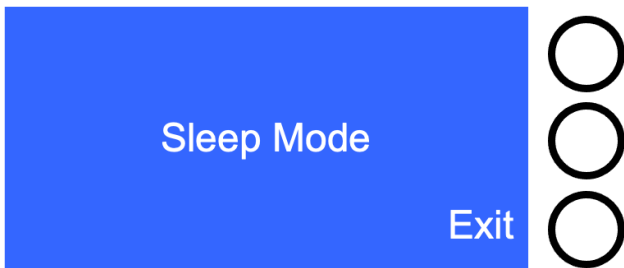

Before shutting down or disconnecting the AutoSpray Station, remove the vials from the Luer ports to prevent liquid from leaking out.

### Milliflex® Rapid reagent and cleaning kits

The AutoSpray Station requires two Milliflex® Rapid kit types:

- Milliflex® Rapid standard reagent kit for detection and enumeration of viable microorganisms
- Milliflex® Rapid cleaning and decontamination kit

See Spare Parts and Accessories. Contact technical assistance for further information.

**Note:** Refer to the user guides supplied with the Milliflex® Rapid kits for instructions on their use.

Once the vials in the reagent kit or the cleaning and decontamination kit are empty, dispose of them in the appropriate waste bin. Do not reuse vial adapters with different vials. Do not pierce a septum more than once as rubber particles may detach.

### Letting the AutoSpray Station go into sleep mode

Before letting the AutoSpray Station go into sleep mode after a Cleaning or Decontamination cycle, or another rinsing or cleaning step, the fluid circuits must be aerated for drying.

1. When the Air screen of the Cleaning or Decontamination function displays, remove the two vials from the Luer ports of the AutoSpray Station.

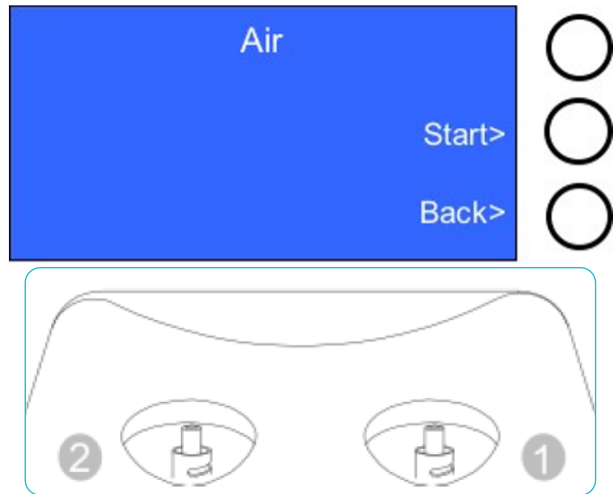

2. Select Start from the Air screen.

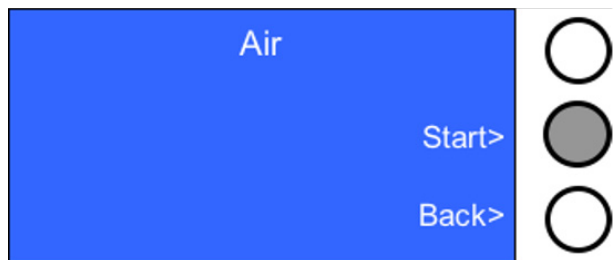

3. The Air cycle starts and a progress bar displays. The air purges the fluid circuits.



4. The Cleaning or Decontamination screen displays, or another rinsing or cleaning step, depending on the procedure.

**Note:** Upon exiting sleep mode, a beep sounds and the pinch valves are closed.

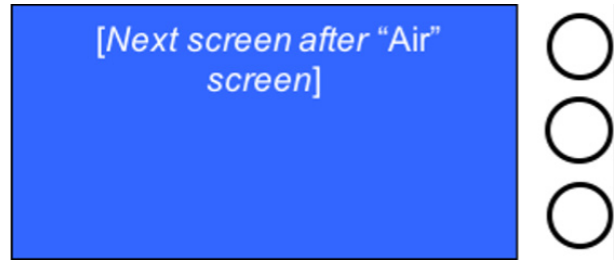
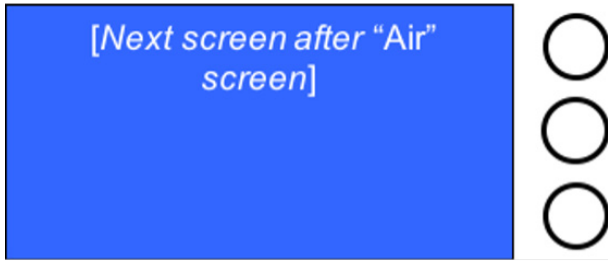

5. If no key is pressed on the AutoSpray Station within one hour, the Sleep Mode screen displays.

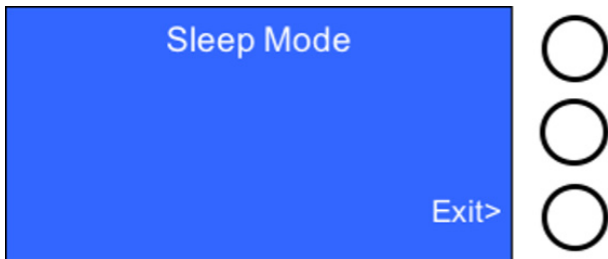

Sleep mode opens the pinch valves.

**Note:** To prevent liquid from leaking out, remove the vials from the Luer ports. Because sleep mode is activated only after completion of the air cycles, there should normally be no vial loaded.

6. Select Exit from the Sleep Mode screen to exit sleep mode and return to the previous screen (the Cleaning or Decontamination screen, or another rinsing or cleaning step, depending on the procedure).

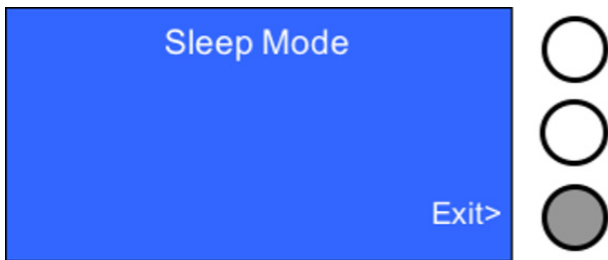

### Installation recommendations

- Install the AutoSpray Station in a clean environment (e.g., microbiology laboratory with limited access and foot traffic). A laminar flow hood environment is preferable as this minimizes the risk of false positive counts triggered by the working environment and particles entering the nebulizers.
- Before placing the AutoSpray Station into a laminar flow hood, carefully disinfect all surfaces of the equipment using a wipe soaked in 70% alcohol. Remove the protective front cover by lifting it vertically and disinfect the entire stainless steel structure of the AutoSpray Station as well as the inside and the outside of the cover itself. Then re-install the cover.
- The AutoSpray Station requires connection to an appropriate power outlet. The electrical circuit must be grounded and protected by a fuse or circuit breaker (see Operator and Equipment Safety Instructions).
- The AutoSpray Station must be positioned close to the Milliflex® Rapid System 2.0 Detection Tower in order to comply with the maximum transfer time for the membrane filter between the AutoSpray Station and the detection tower (no more than 60 seconds). The two instruments should be in the same room.

## Setting up the AutoSpray Station

### Installing the AutoSpray Station

**Important:** To prevent contamination, do not touch with your hands the Luer ports on the AutoSpray Station, including the Luer connections of the vials, the air outlet Luer connections, the Millex™-FG filter Luer connections, or the ends of the nebulizers. Wear gloves whenever handling the equipment and reagents in order to prevent any operator-induced false positive readings.

Do not connect the AutoSpray Station to a power outlet until the first ten steps in the procedure that follows have been completed.

1. Place the AutoSpray Station on a flat, stable surface, away from any source of excessive heat or vibration. The AutoSpray Station must be installed near a power outlet.
2. Remove the protective front cover by lifting it vertically.

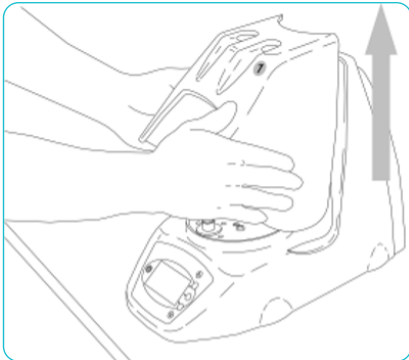

3. Disinfect all surfaces with a wipe soaked in 70% alcohol: this includes the turntable, the stainless steel caps, the Luer ports, the membrane holder, the pad holder, the entire stainless steel structure, and the inside and outside of the protective front panel. Let the alcohol evaporate.
4. Install the turntable by inserting the three turntable pins into the three corresponding holes on the base of the AutoSpray Station.

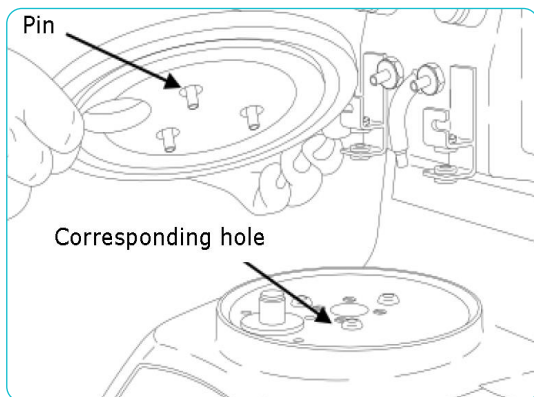

5. Fit Millex™-FG filters to the AutoSpray Station's two air connectors. The shorter female side (inlet) connects to the air outlet of the instrument. Press firmly into place while rotating slightly.



6. Fit the two nebulizers to the AutoSpray Station. Proceed as follows for each nebulizer:

**Important:** Each nebulizer is identified by a serial number engraved on its side. The same serial number is shown on the nebulizer box, along with an adhesive sticker labeled 1 or 2.

Install the nebulizer contained in the box marked 1 in the right-hand position on the AutoSpray Station. Install the nebulizer marked 2 in the left-hand position.

**Caution:** Interchanging the nebulizers will invalidate the spraying volume calibration performed by the supplier, and the nebulizer volumes will require readjustment.

- a. Remove the two protective caps from each end of the nebulizer.

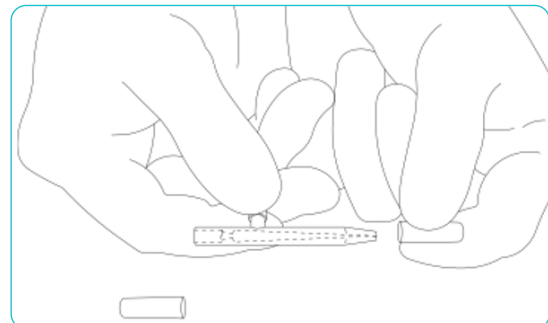

- b. Fit the nebulizer to the nebulizer holder on the AutoSpray Station. Pass the conical end of the nebulizer through the rubber O-rings on the nebulizer holder.

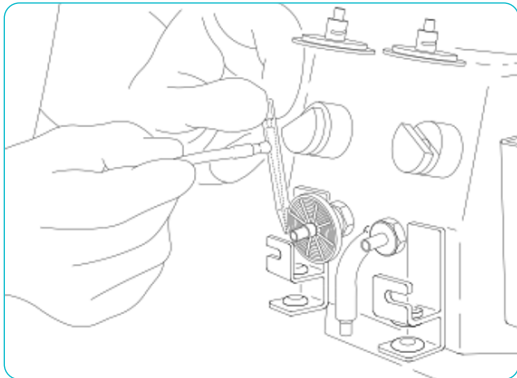

- c. Pivot the nebulizer to insert its air inlet tube into the corresponding slot on the AutoSpray Station.

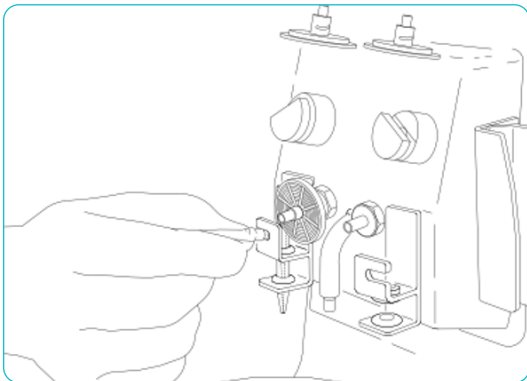

- d. Connect the nebulizer's air inlet tube to the corresponding Millex™-FG filter mounted in step 5.

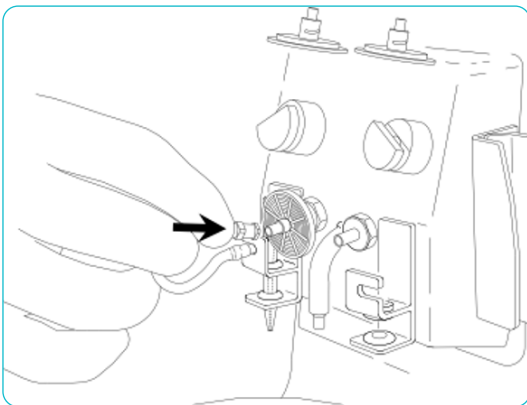

7. Fit the silicone tubes for both fluid circuits.

- a. Insert the tube into the pinch valve by holding the tube on either side of the pinch valve and pushing it downwards as far as it will go.

**Note:** Insert the tube at its midpoint so that equal lengths remain upstream and downstream of the pinch valve.

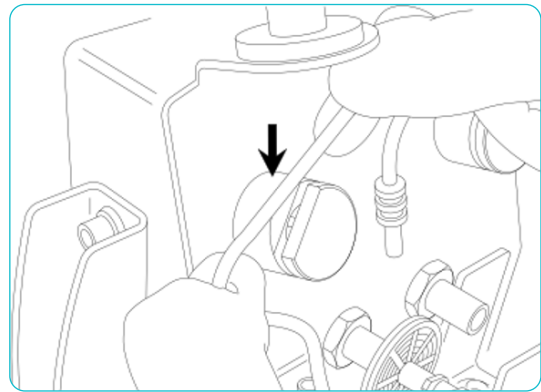

Insert the end of the silicone tube's upper section as far as it will go into the AutoSpray Station's Luer port outlet. The tube must form a loop between the pinch valve and the Luer port's outlet to prevent the tubing from pinching or kinking. Reposition the tubing if the tubing becomes kinked or pinched.

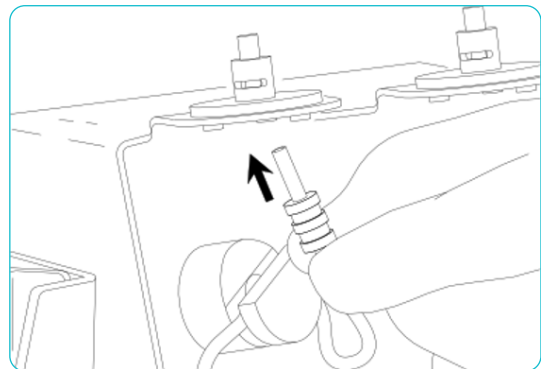

b. Insert the end of the silicone tube's lower section as far as it will go into the nebulizer's inlet port. The tube must form a loop between the pinch valve and the nebulizer's inlet port to prevent pinching or kinking the tubing. Reposition the tubing if the tubing becomes kinked or pinched.

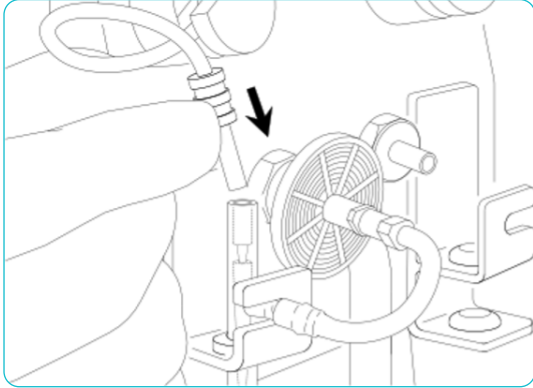

8. Fit a Millex™-FG filter into the air drying outlet.

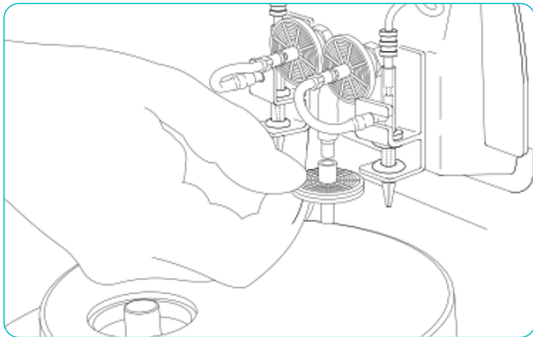

9. Fit the protective front cover back on vertically, ensuring that the guides fit properly into the guide grooves.

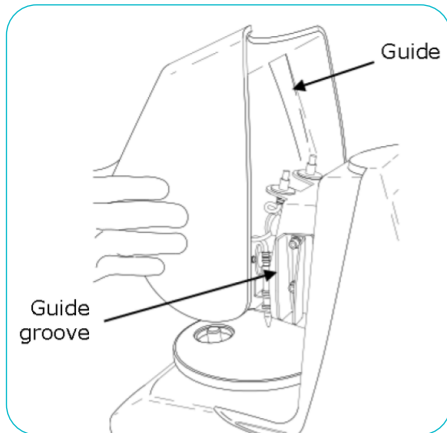

10. Fit the two stainless steel caps onto the Luer ports.



11. Connect the DC power unit to the appropriate power cable.

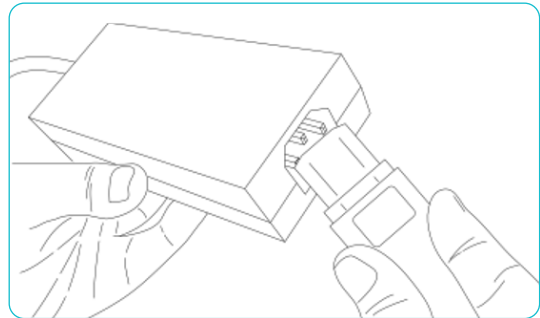

12. Connect other end of the power cable to a grounded 100–240 V, 50–60 Hz power outlet.

13. Connect the DC power unit's outlet cable to the power input at the rear of the AutoSpray Station.

## Preparing the AutoSpray Station for its first use

**Important:** The following procedure must be applied immediately after installing the AutoSpray Station and before using it for the first time.

1. Disinfect all surfaces with a wipe soaked in 70% alcohol: this includes the turntable, the stainless steel caps, the Luer ports, the membrane holder, and the pad holder.
2. Run a Decontamination cycle on the AutoSpray Station (see Decontamination function).
3. Run a Cleaning cycle (see Cleaning function).
4. Verify the volume sprayed by the nebulizers (see Volume Verification function) using the Autospraying function. Measure the volume three times for each nebulizer.
5. For each nebulizer, compare each of the three values with the following tolerances:

Autospraying function:  $25 \leq \text{Vol. } (\mu\text{L}) \leq 45$

If all three values measured fall within these tolerances, the AutoSpray Station is ready for use.

6. If one or more of the values measured falls outside these tolerances, run a Volume Adjustment cycle (see Volume Adjustment function) in order to bring the volumes within the above tolerances.

## Using the AutoSpray Station

### Basic operations

**Caution:** Wear gloves whenever handling the equipment and reagents to prevent any operator-induced false-positive results.

### Changing the holders

Two types of holders are included with the AutoSpray Station, both of which can be fitted into the dedicated bay in the turntable:

- The absorbent pad holder, which is the holder needed for the Priming, Cleaning, and Decontamination functions
- The Milliflex Oasis<sup>®</sup> membrane filter holder, which is the holder needed for spraying and drying the Milliflex Oasis<sup>®</sup> membrane filters

**Note:** Every day the AutoSpray Station is used, the membrane holder and pad holder should be carefully disinfected beforehand using a wipe soaked in 70% alcohol. The holders should be autoclaved every week.

Insert the required holder into the bay on the turntable, as shown in the following illustrations. Slight pressure is required to fit the membrane filter holder.

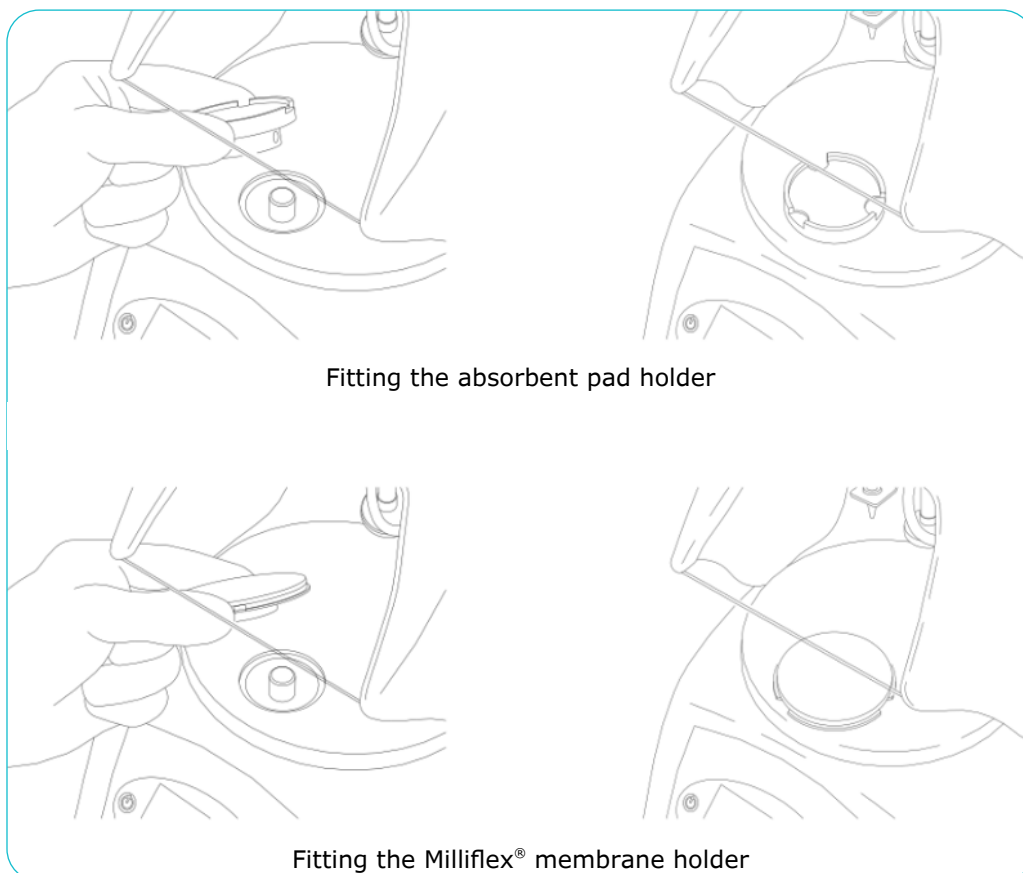

## Installing the vials

Refer to the instructions supplied with the Milliflex® Rapid cleaning and decontamination kit or the reagent kits in order to properly prepare the vials they contain for use.

1. Remove the two stainless steel caps from the Luer ports.

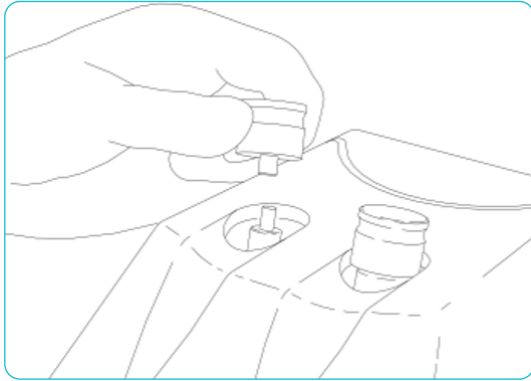

**Note:** Avoid contaminating the Luer port's stainless steel caps. Always leave the caps in a laminar flow hood, and avoid touching the Luer ports. When not used, position the caps with the Luer side facing upwards. These caps may be autoclaved (the requirement is 121 °C for 15 minutes or 134 °C for 5 minutes) or chemically disinfected. They should be autoclaved every time the AutoSpray Station is decontaminated (see Maintenance).

2. Mount the vials onto the Luer ports.

**Note:** Avoid contaminating the AutoSpray Station's Luer ports and the Luer connection of the vial adapters. As shown in the illustration, always hold the vial adapter when screwing the vials smoothly into position. Holding the vial itself may damage the septum.

**Note:** Store the reagent vials at a temperature of between 2 and 5 °C, but use them at ambient temperature. Equilibrate the reagents to ambient temperature in an upright position before running a cycle. Vials may leak if inverted immediately after cooling at 2 to 5 °C due to the air inside the vials warming and thus pressure building up.

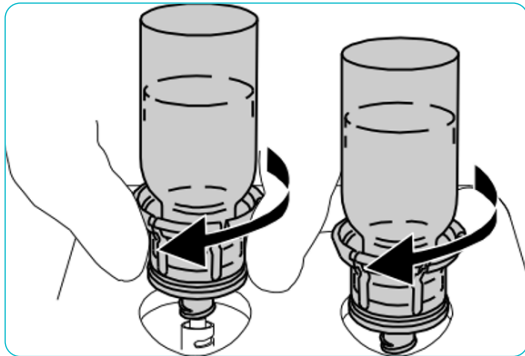





**Caution:** When the AutoSpray Station is not in use, always fit the stainless steel caps onto the Luer ports to prevent particles entering the nebulizer.

## The main functions of the AutoSpray Station

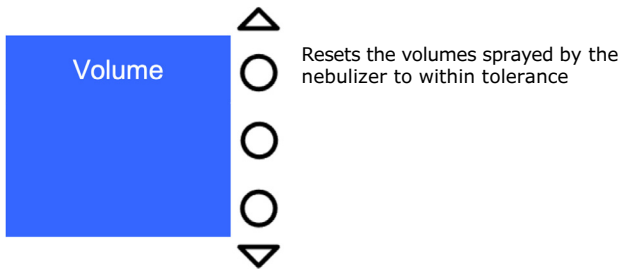
The AutoSpray Station's control panel features two scroll keys and three selection keys, all positioned to the right of the display. The keys are used to navigate through the menu, to change settings and to make selections.

Autospraying	▲	Runs consecutively: spray Reagent 1, dry membrane, and spray Reagent 2.
	○	An initial drying step may be added (see the pre-drying option in Menu function)
	○	
Cleaning	○	Cleans the fluid circuits
	○	
Priming	○	Primes the fluid circuit
	▼	
Reagent 1	▲	Sprays Reagent 1 using only Nebulizer 1 (the one on the right). An initial drying step may be added (see the pre-drying option in Menu function)
	○	
	○	
Reagent 2	○	Sprays Reagent 2 using only Nebulizer 2 (the one on the left)
	○	
Membrane	○	Dries membrane only
	▼	
Menu	▲	Accesses the AutoSpray Station's configuration sub-menus (options and settings)
	○	
Verification	○	Tests the internal timer
	○	
Decontamination	○	Decontaminates all the fluid circuits
	▼	



Use the Up and Down   keys to scroll through a screen (scrolling three lines at a time) or, in some instances, to change a selected setting (the date, for example). To make a selection press the  key next to the function of your choice.

### Powering up the AutoSpray Station

1. Press the ON/OFF key to the left of the display.

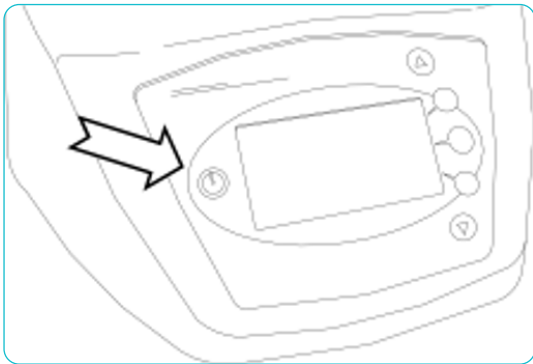

**Note:** If the AutoSpray Station has been disconnected, it powers up as soon as it is reconnected.

When the AutoSpray Station powers up, the pinch valves are actuated and close the fluid tubes, generating an audible click.

The AutoSpray Station boots up.



**Note:** The date set in the AutoSpray Station displays in DD MMM YYYY (day-month-year) format.

After a few seconds, the display shows the number of spray cycles remaining before the next volume adjustment is due.

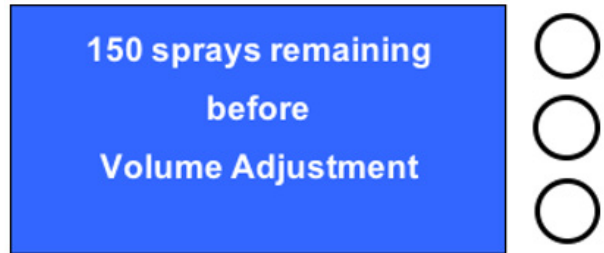

After another few seconds, the screen recommends cleaning.

**Note:** If this is to be the system's first use of the day, select and complete a Cleaning cycle prior to using the system.

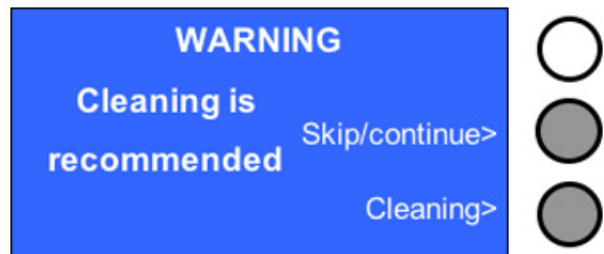

2. Do one of the following:

- Select Skip/continue to ignore the warning
- OR
- Select Cleaning to start a Cleaning cycle (see Cleaning function).

When the Cleaning cycle is over or if Skip/continue is pressed, a screen recommends a Priming cycle. When reagents are loaded, a Priming cycle must be selected for proper reagent coverage. This function will prime the nebulizers with the reagents.

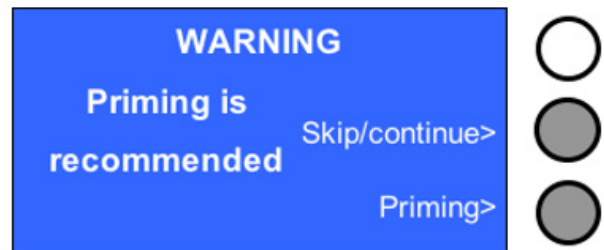

3. Do one of the following:

- Select Skip/continue to ignore the warning  
OR
- Select Priming to start a Priming cycle (see Priming function).

When the Priming cycle is over or if Skip/continue is pressed, the Main Menu displays, listing the AutoSpray Station's operating functions (top three shown in screenshot below). The AutoSpray Station is now ready for use.

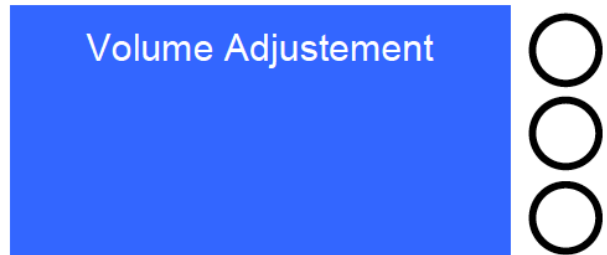
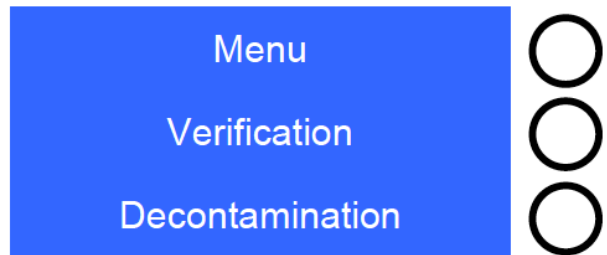
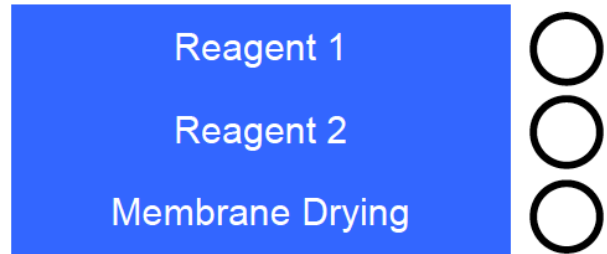
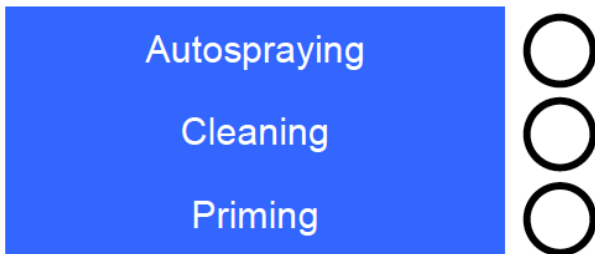
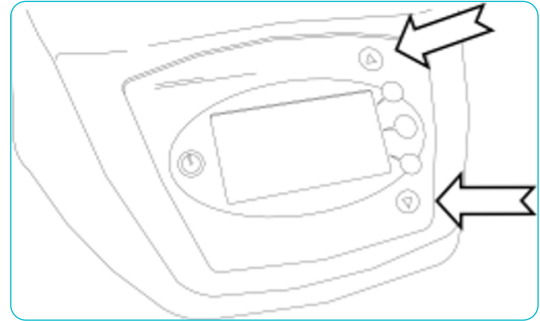

### Using the AutoSpray Station

#### Main Menu

Use the Main Menu to select one of the following functions:

- Autospraying
- Cleaning
- Priming
- Reagent 1
- Reagent 2
- Membrane drying
- Menu (configuration and options)
- Verification
- Decontamination
- Volume adjustment

1. From the Main Menu, use the up and down keys to scroll through the menu (three lines at a time).

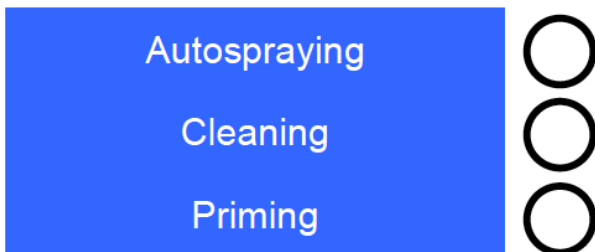

2. Select the required function by pressing the corresponding key to the right of the displayed function.

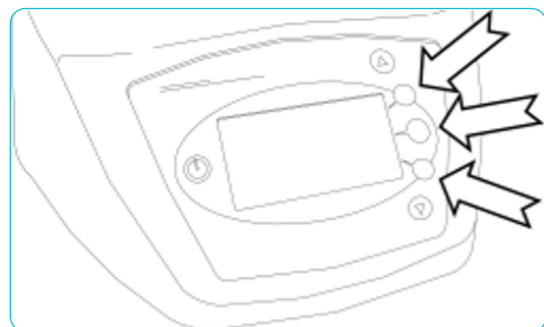

## Autospraying function

Use this function to spray the reagents from the Milliflex® Rapid standard reagent kit (see Spare Parts and Accessories) for detection and total viable count determination by ATP bioluminescence. It carries out the following automated operations consecutively:

- Application of Reagent 1
- Membrane drying
- Application of Reagent 2

This function delivers a volume of 35 µL ±10 µL per reagent. If necessary, a preliminary drying step can also be programmed (see Setting Pre-Drying Off/On).

1. Mount the reagent vials onto the two Luer ports at the top of the AutoSpray Station as follows:

- Reagent 1 must be placed in the right-hand port.
- Reagent 2 must be placed in the left-hand port.

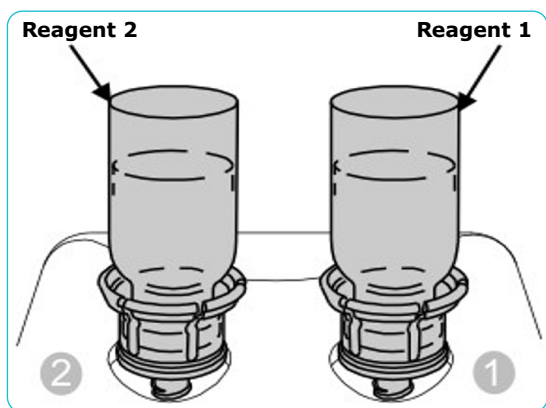

**Important:** If the reagent vials have been freshly mounted, run a Priming cycle (see Priming function) before starting the first spraying cycle.

**Note:** Store the reagents at a temperature of between 2 and 5 °C, but use them at ambient temperature. Equilibrate the vials to ambient temperature in an upright position before starting a cycle. Vials may leak if inverted immediately after cooling at 2 to 5 °C due to the air inside the vials warming and thus pressure building up.

2. Install the membrane filter holder (see Changing the Holders) and place a dry Milliflex Oasis® Rapid membrane on the holder.

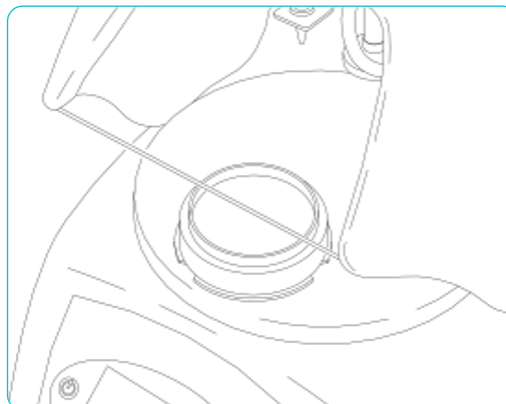

3. Select Autospraying from the Main Menu screen.

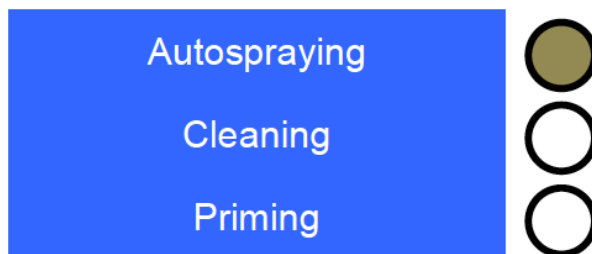

The Autospraying screen displays.

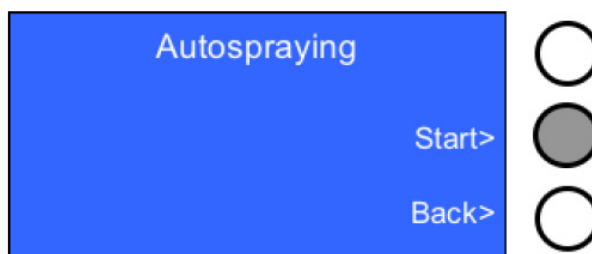

4. Select Start to start an automatic spraying cycle.

**Note:** Select Back to quit and return to the Main Menu.

The Autospraying cycle starts, and a progress bar displays.

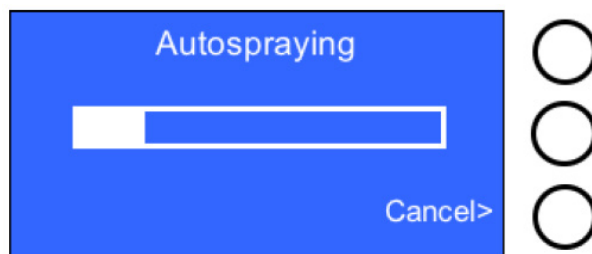

The membrane holder rotates and moves to Position 1 (see Reagent Dispensing and Drying) while Nebulizer 1 sprays Reagent 1 from the right-hand vial onto the membrane.

When completed, the membrane holder continues to rotate and move to Position 2 where sterile air dries the membrane.

The membrane holder then continues to rotate and move to Position 3 where Nebulizer 2 sprays Reagent 2 onto the membrane from the left-hand vial.

The membrane holder returns to Position 0 at the end of the Autospraying function. The entire Autospraying cycle takes approximately 2 minutes.

**Note:** If the pre-drying option is selected, the Autospraying cycle is preceded by membrane pre-drying (see Setting Pre-Drying Off/On).

**Note:** Select Cancel to stop the current cycle and return to the Autospraying screen.

**Caution:** If the AutoSpray Station is stopped during a spraying cycle, run a Priming cycle before resuming the procedure (see Priming function).

5. At the end of the spraying cycle, the display returns to the Autospraying screen:

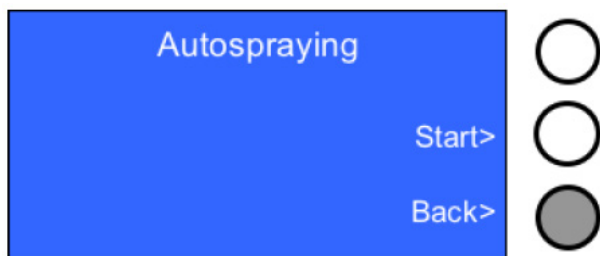

6. Select Back to quit and return to the Main Menu.

**Note:** Select Start to start another Autospraying cycle (refer to step 4 of the procedure).

The membrane filter is now ready to be placed on the Milliflex® Rapid System 2.0 Detection Tower for analysis. To minimize the reduction in the bioluminescence signal, transfer the membrane from the AutoSpray Station to the Detection Tower within one minute. Place the lid on the Milliflex Oasis® Rapid membrane during transfer to minimize evaporation of the bioluminescence reagent.

**Note:** After spraying Reagent 2, the wetter areas of the membrane can be seen to form concentric rings. This has no effect on the quality of detection or image processing because sufficient reagent will have been deposited over the entire surface of the membrane.

Similarly, the images obtained with the Milliflex® Rapid System 2.0 Detection Tower may also show concentric color rings. This has no effect on the quality of detection or image processing.

Example below: Image obtained with the Milliflex® Rapid System 2.0 Detection Tower after spraying both reagents onto a membrane filter after filtering 100 mL of sterile water.

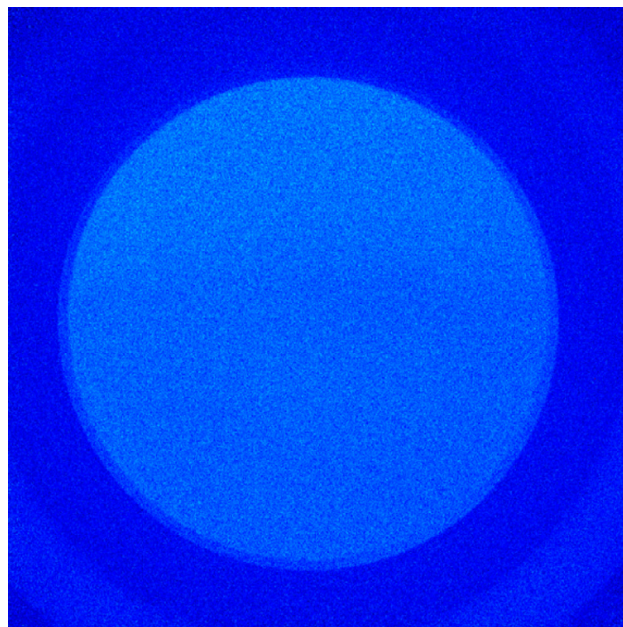

Image without any colony: count = 0

**Note:** The membrane's appearance may differ somewhat from this example.

**Caution:** If a same Luer port is used to spray both the ATP bioluminescence reagents (using the Autospraying function), conduct a cleaning procedure between using the two types of reagents (see Cleaning function).

### Cleaning function

Use this function before and after each day's use to clean the AutoSpray Station's entire fluid circuit (tubing and nebulizers). A Cleaning cycle consists of six individual cycles, performed in the following order:

- Rinsing Agent cycle
- Air cycle
- Cleaning Agent cycle
- Air cycle
- Rinsing Agent cycle
- Air cycle

A full Cleaning cycle takes about 10 minutes.

The Milliflex® Rapid cleaning and decontamination kit contains the rinsing agent and cleaning agent vials needed, as well as decontamination agent. Their formulations have been optimized for cleaning and maintaining the AutoSpray Station's fluid circuits and sensitive nebulizers (see Spare Parts and Accessories).

**Caution:** Do not use other fluids to clean or decontaminate the AutoSpray Station's fluid circuits. Never use alcohol. Doing so could result in precipitation of the proteins contained in the bioluminescence reagent.

Any failure to comply with the cleaning frequency, procedure, and/or recommended cleaning fluids may lead to clogging of the nebulizers, which will affect the volume of reagents sprayed. If clogging occurs, see Troubleshooting.

This is how to proceed to perform a Cleaning cycle:

1. Select Cleaning from the Main Menu screen.

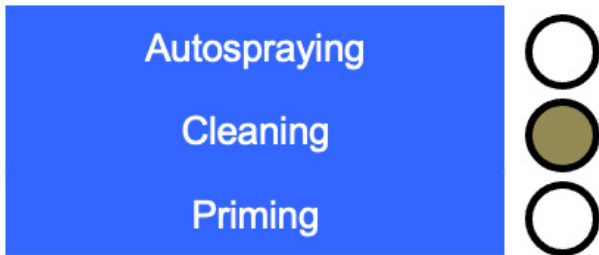

**Note:** The Cleaning function can also be accessed directly from the "WARNING Cleaning is recommended" screen displayed when the AutoSpray Station is powered up or shut down.

The Cleaning screen displays.

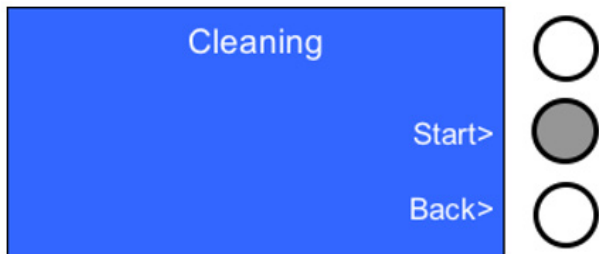

2. Select Start to start the cycle.

**Note:** Select Back to quit and return to the Main Menu.

The Rinsing Agent screen displays.

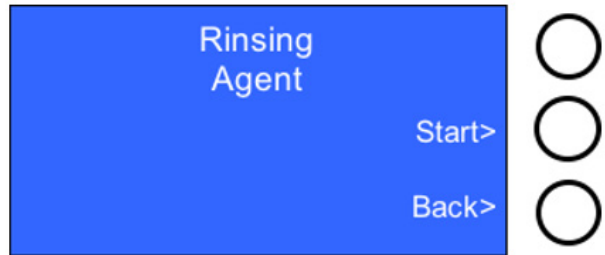

3. Mount vials of rinsing agent (white label) to both Luer ports.

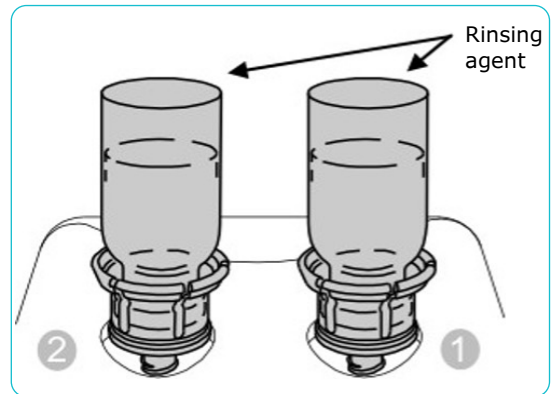

4. Fit the absorbent pad holder (see Changing the Holders). Place three absorbent pads on the holder.

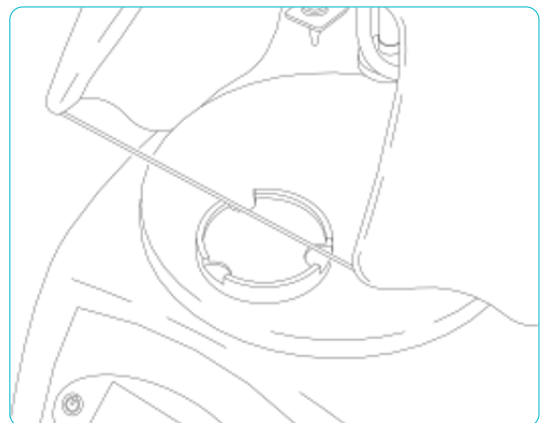

5. Select Start from the Rinsing Agent screen to start a Rinsing cycle.

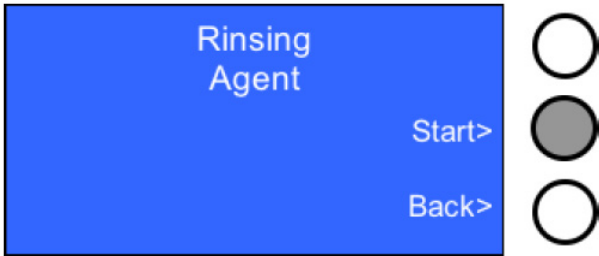

**Note:** Select Back to quit and return to the Cleaning screen.

Rinsing starts, and a progress bar displays.



The rinsing agent flows first through Nebulizer 1 and then through Nebulizer 2. The rinsing agent is soaked up by the absorbent pads.

**Note:** Select Cancel to stop the current cycle and return to the Rinsing Agent screen.

At the end of the Rinsing cycle, the Air screen displays.

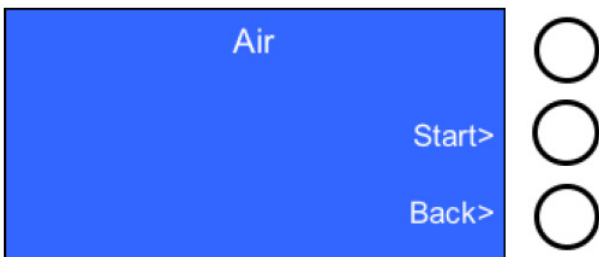

6. Remove the two vials of rinsing agent.

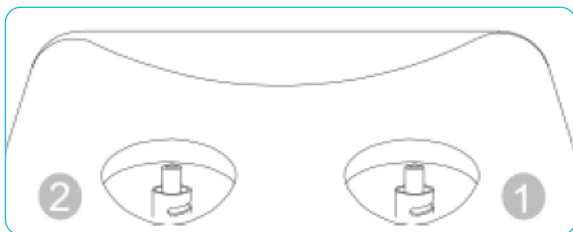

7. Select Start from the Air screen.

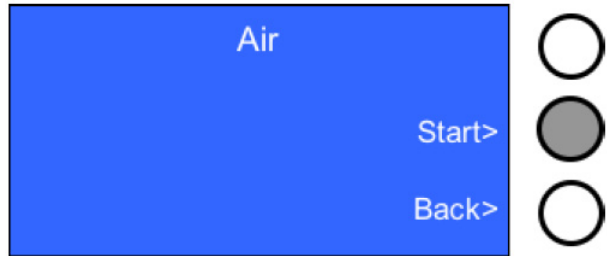

**Note:** Select Back to quit and return to the Rinsing Agent screen.

The air purge cycle starts for both nebulizers, and a progress bar displays.



The air purges the fluid circuits.

**Note:** Select Cancel to stop the current cycle and return to the Air screen.

At the end of the Air cycle, the Cleaning Agent screen displays.

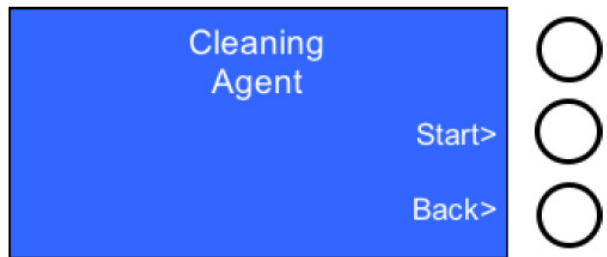

8. Mount vials of cleaning agent (yellow label) to both Luer ports

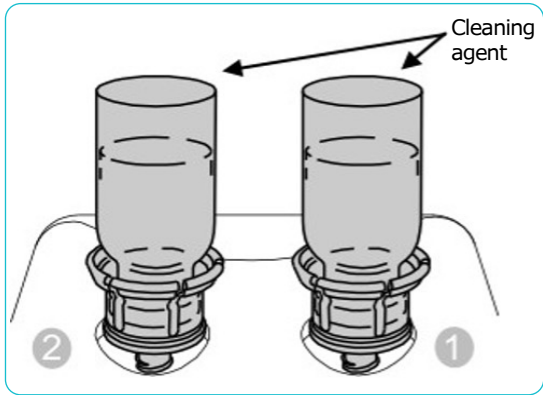

9. Select Start from the Cleaning Agent screen to start a Cleaning cycle.



**Note:** Select Back to quit and return to the Air screen.

The Cleaning Agent cycle starts for both nebulizers, and a progress bar displays.

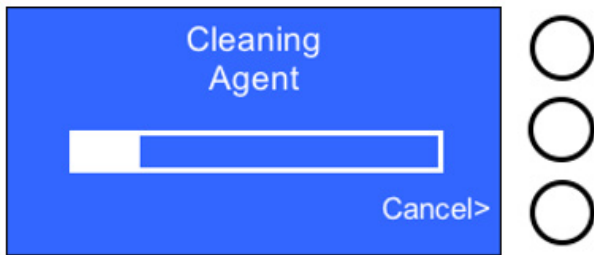

The cleaning agent flows first through Nebulizer 1, and then through Nebulizer 2. There is a pause while the pad holder remains under Nebulizer 2 to allow sufficient contact time for thorough cleaning before spraying resumes. The cleaning agent is soaked up by the absorbent pads.

**Note:** Select Cancel to stop the current cycle and return to the Cleaning Agent screen.

At the end of the Cleaning Agent cycle, the Air screen displays.

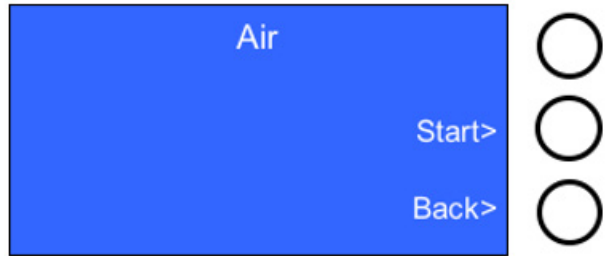

10. Remove the two vials of Cleaning agent.

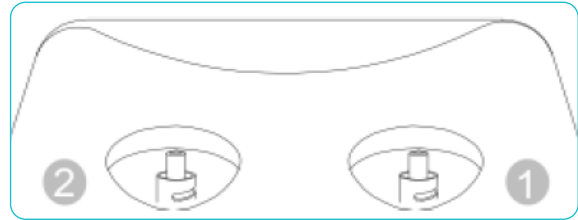

11. Select Start from the Air screen.

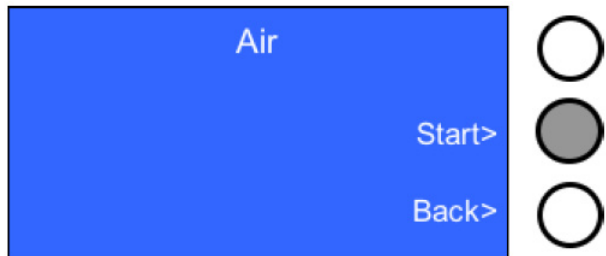

**Note:** Select Back to quit and return to the Cleaning Agent screen.

The second Air cycle then starts for both nebulizers, and a progress bar displays. The air purges the fluid circuits.

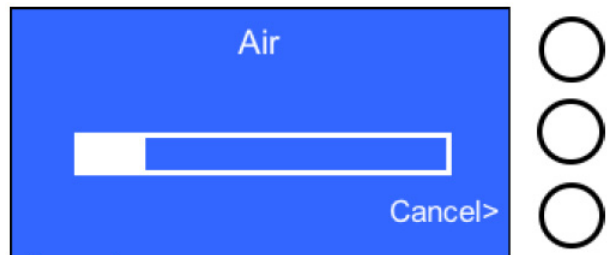

**Note:** Select Cancel to stop the current cycle and return to the Air screen.

At the end of the Air cycle, the Rinsing Agent screen displays.



The rinsing agent rinses Nebulizer 1 first, and then Nebulizer 2. There is a pause while the pad holder remains under Nebulizer 2 to ensure thorough rinsing before continuing. The rinsing agent is collected by the absorbent pads.

**Note:** Select Cancel to stop the current cycle and return to the Rinsing Agent screen.

At the beginning of the pause in this Rinsing Agent cycle, the pinch valve opens for a very short period, allowing a little rinsing agent to enter the nebulizer outlet (inside as well as outside the capillary tube). The liquid is eliminated from the outside of the capillary tube when spraying resumes.

12. Install vials of rinsing agent to both Luer ports.

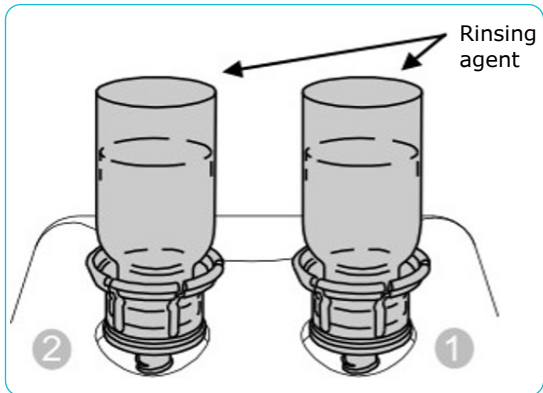

At the end of the Rinsing Agent cycle, the Air screen displays.

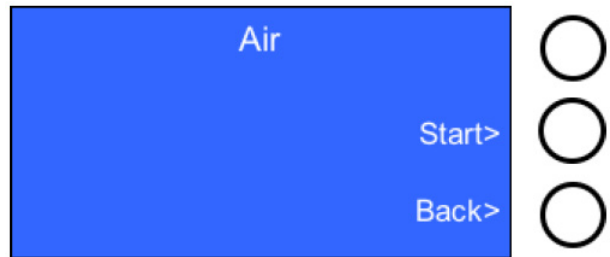

13. Select Start from the Rinsing Agent screen to start a rinsing cycle.

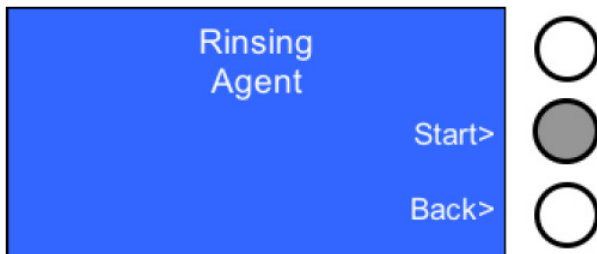

**Note:** Select Back to quit and return to the Air screen.

The Rinsing Agent cycle starts, and a progress bar displays.

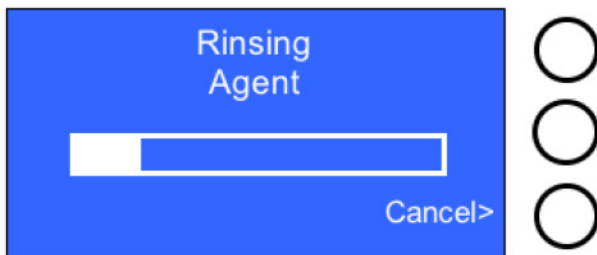

14. Remove the two vials of Rinsing agent.

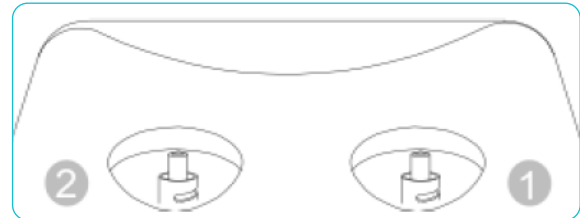

15. Select Start from the Air screen.

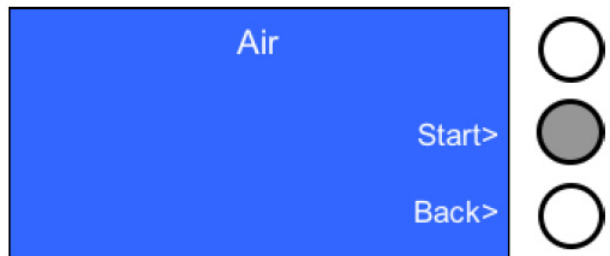

**Note:** Select Back to quit and return to the Rinsing Agent screen.

The third and final Air cycle starts for both nebulizers, and a progress bar displays.



The air purges the fluid circuits.

**Note:** Select Cancel to stop the current cycle and return to the Air screen.

16. At the end of the Air purge cycle, return to the Cleaning screen:

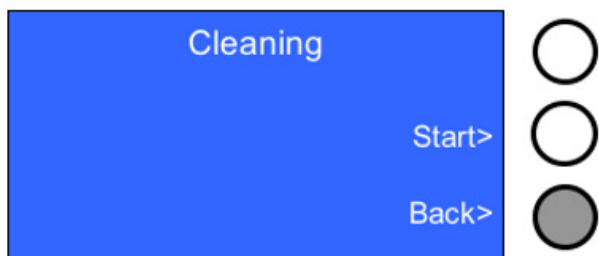

17. Do one of the following:

- Select Back to quit.

OR

- Select Start to start another Cleaning cycle.

**Note:** If the Cleaning function is run when shutting down the AutoSpray Station, shutdown is performed automatically at the end of that Cleaning cycle. After cleaning, fit the stainless steel caps onto the Luer ports.

If Back is selected, the screen may recommend a Priming cycle:

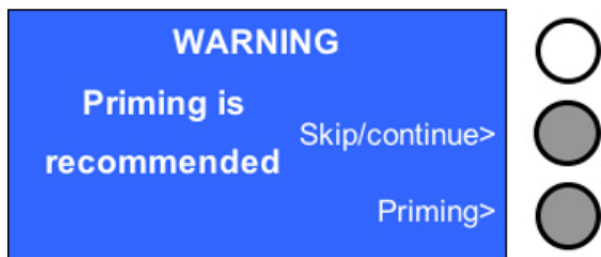

18. Check under which circumstances a Priming cycle is necessary (see Priming function). Do one of the following:

- Select Skip/continue to ignore the warning and return to the Main Menu.

OR

- Select Priming to start the cycle (see Priming function).

### Priming function

This function primes both fluid circuits and their respective nebulizers with appropriate reagent (Reagent 1 or Reagent 2). This is necessary to enable proper flowing and spraying onto the filter membrane.

Run this function under the following circumstances:

- After the reagents have been mounted to the AutoSpray Station's ports, prior to running samples
- After a deliberate stoppage of any spraying cycle (Autospraying, Reagent 1, or Reagent 2 functions)
- After changing a vial of reagent

**Note:** After instrument power-up, a recommendation to perform priming is displayed immediately after cleaning.

Only one nebulizer can be primed at a time. If both nebulizers are needed (e.g. when using the Autospray function), both must be primed individually, one after the other.

This is how to perform a Priming cycle:

1. Install the absorbent pad holder (see Changing the Holders) and fit 3 pads to the absorbent pad holder.

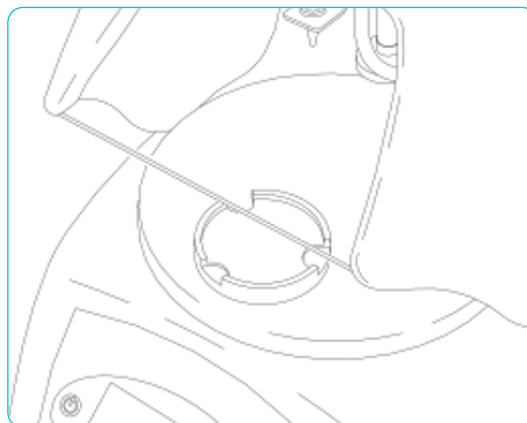

2. Select Priming from the Main Menu.



**Note:** The Priming function can also be accessed directly from the "WARNING Priming is recommended" screen (displayed at the end of a Cleaning cycle or when the AutoSpray Station is powered up).

The Priming screen displays.

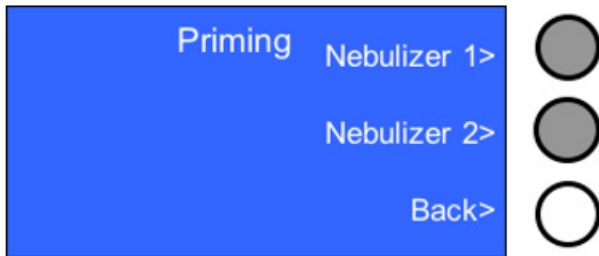

3. Do one of the following:

- Select Nebulizer 1 to start the Priming cycle for Nebulizer 1 (right).

OR

- Select Nebulizer 2 to start the Priming cycle for Nebulizer 2 (left).

**Note:** Select Back to quit and return to the Main Menu.

The following description assumes Nebulizer 1 was selected. This displays the Priming Reagent 1 Nebulizer 1 right screen. The procedure is the same when selecting Nebulizer 2. In this case, the name of the following screen is Priming Reagent 2 Nebulizer 2 left.

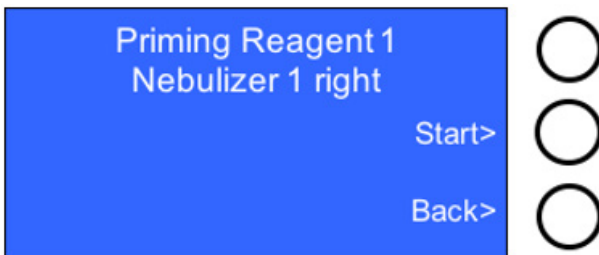

4. Install the reagent vial on the appropriate Luer port for the nebulizer and its fluid circuit to be primed:

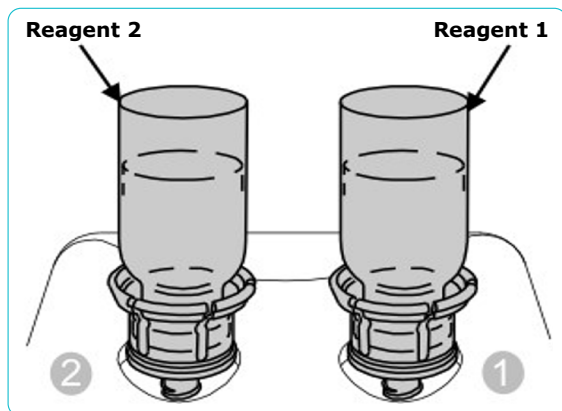

- Reagent 1 for the right-hand nebulizer and
- Reagent 2 for the left-hand nebulizer

5. Select Start from the Priming Reagent 1 Nebulizer 1 right screen.

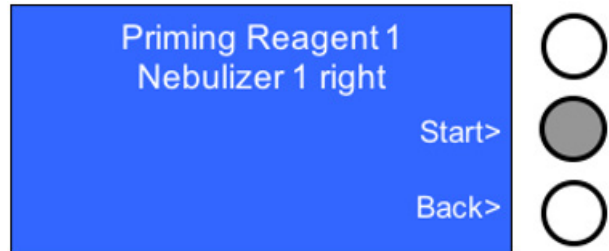

**Note:** Select Back to return to the Priming screen.

The selected nebulizer's priming cycle starts and a progress bar displays.

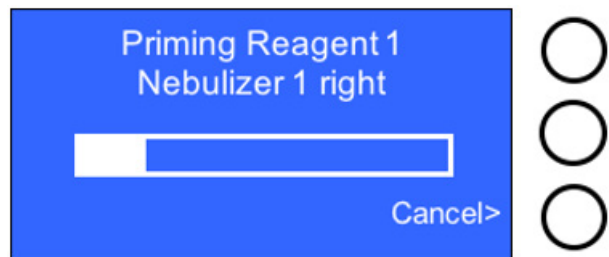

**Note:** Select Cancel to stop the current cycle and return to the Priming screen.

6. At the end of the cycle, the Priming screen returns:

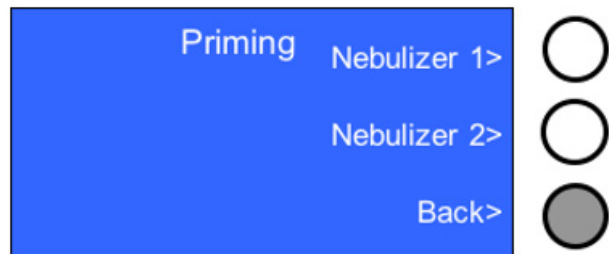

7. Do one of the following:

- Select Back to quit and return to the Main Menu.

OR

- Select Nebulizer 1 or Nebulizer 2 to start a new Priming cycle (e.g., to prime the other nebulizer and its fluid circuit).

## Reagent 1 Spraying function

This function uses only Nebulizer 1 (the right-hand nebulizer). Use it to spray Reagent 1 onto several membranes at a time. The Reagent 1 function delivers a volume of 35  $\mu\text{L} \pm 10 \mu\text{L}$  per membrane.

This function is run using a vial of ATP releasing reagent (Reagent 1) installed in the right-hand Luer port.

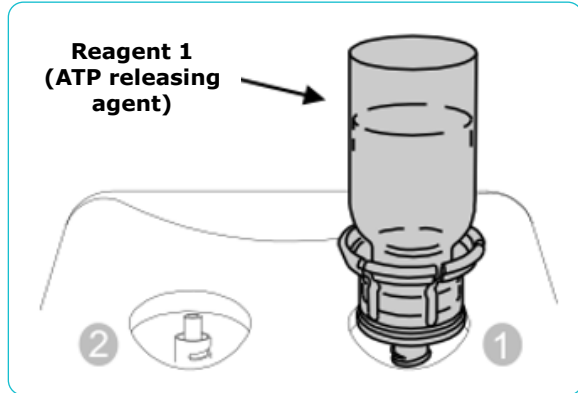

**Important:** If the ATP releasing reagent is freshly loaded, run a Nebulizer 1 Priming cycle (see Priming function) before starting a Reagent 1 Spraying cycle.

**Note:** Store the reagents at a temperature between 2 and 5  $^{\circ}\text{C}$ , but use them at ambient temperature. Equilibrate the reagents to ambient temperature in an upright position before starting any cycle. Vials may leak if inverted immediately after cooling at 2 to 5  $^{\circ}\text{C}$  due to the air inside the vials warming and thus pressure building up.

1. Install the membrane holder (see Changing the Holders) and place a dry Milliflex Oasis<sup>®</sup> Rapid membrane sample on the holder.

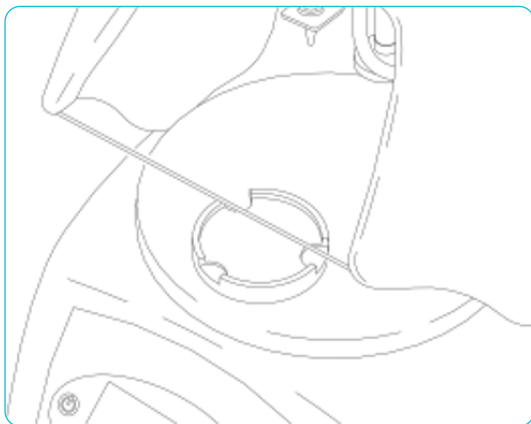

2. Select Reagent 1 from the Main Menu screen.

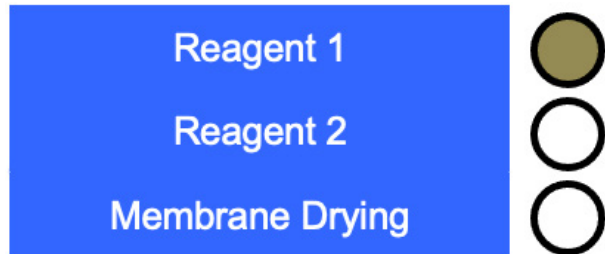

The Reagent 1 screen displays.

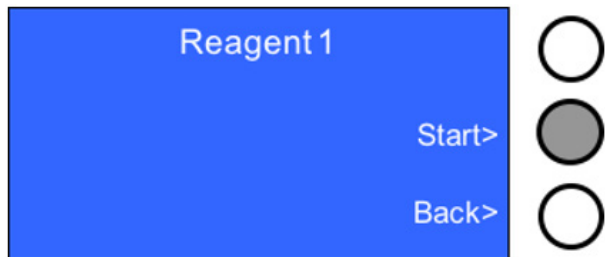

3. Select Start to start the cycle.

**Note:** Select Back to quit and return to the Main Menu.

The Reagent 1 cycle starts, and a progress bar displays.

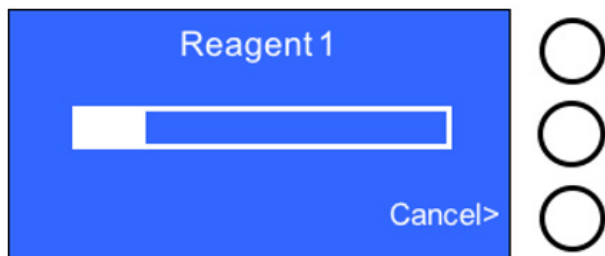

The membrane holder rotates and moves under Nebulizer 1. The pinch valve opens to spray Reagent 1 onto the spinning membrane filter. The turntable moves the spinning membrane in a small arc under the spraying nebulizer to dispense the aerosol onto the membrane.

At the end of the spraying cycle, the membrane holder returns to Position 0.

**Note:** If the pre-drying option is selected, the spraying cycle for Reagent 1 is preceded by membrane pre-drying (see Setting Pre-Drying Off/On).

Select Cancel to stop the current cycle and return to the Reagent 1 screen.

**Caution:** If the spray cycle is canceled, run a Nebulizer 1 Priming cycle before restarting the procedure (see Priming function).

4. At the end of the Reagent 1 cycle, return to the Reagent 1 screen:

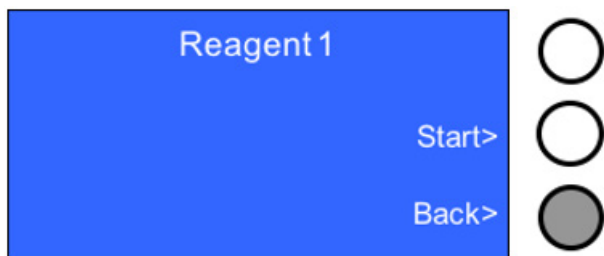

5. Do one of the following:

- Select Back to quit and return to the Main Menu.
- OR
- Select Start to start another Reagent 1 cycle.

**Note:** Since the main constituent of the ATP releasing reagent is alcohol, the surface of the membrane does not appear wet after application of this reagent.

### Reagent 2 Spraying function

This function uses only Nebulizer 2 (left-hand nebulizer). Use this function to spray 35 µL ±10 µL of Reagent 2 onto a sample's membrane filter previously sprayed with Reagent 1 using the Reagent 1 function (see above) and dried. The membrane filter must be completely dry before spraying Reagent 2, so either perform a Drying cycle (see Membrane Drying function) or leave the membrane filter to dry in the laminar flow hood before commencing.

This function is run using a vial of bioluminescence reagent (Reagent 2) installed in the left-hand position.

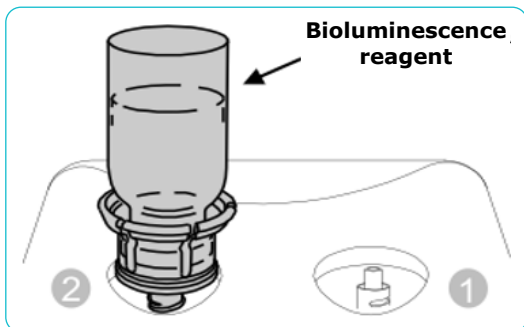

**Important:** If the bioluminescence reagent is freshly loaded, run a Nebulizer 2 priming cycle (see Priming function) before starting a Reagent 2 Spraying cycle.

1. Ensure the membrane holder is installed (see Changing the Holders) and place the dry Milliflex® Rapid membrane sample on the holder.

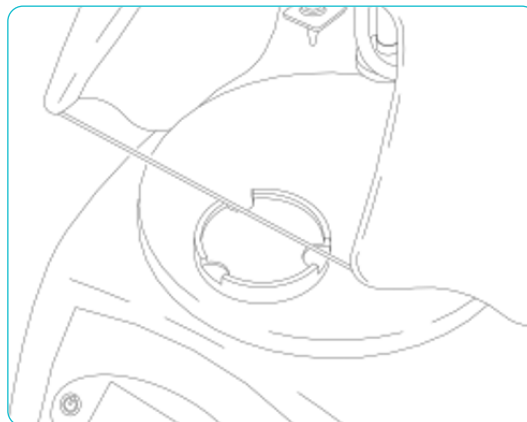

2. Select Reagent 2 from the Main Menu.

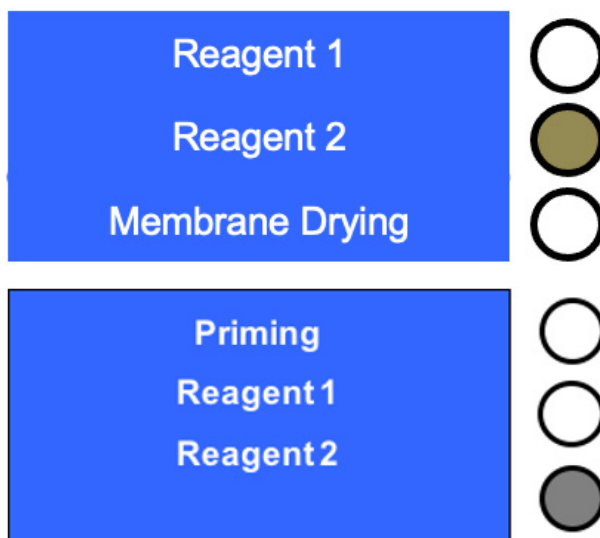

The Reagent 2 screen displays.

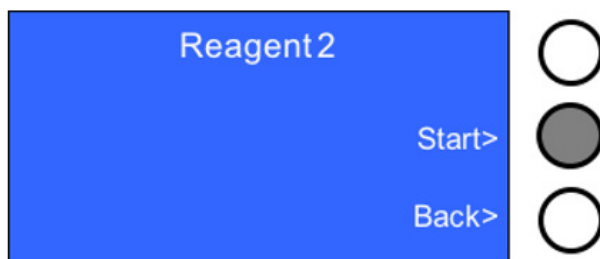

3. Select Start to start the cycle.

**Note:** Select Back to quit and return to the Main Menu.

The Reagent 2 cycle then starts and a progress bar displays.

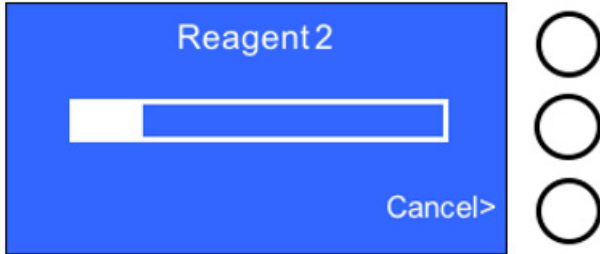

The membrane holder rotates and moves under Nebulizer 2. The pinch valve opens to spray Reagent 2 onto the spinning membrane. The turntable moves the spinning membrane in a small arc under the spraying nebulizer to dispense the aerosol onto the membrane.

At the end of the cycle, the membrane holder returns to Position 0.

**Note:** Select Cancel to stop the current cycle and return to the Reagent 2 screen.

**Caution:** If the spray cycle is canceled, run a Nebulizer 2 Priming cycle before restarting the procedure (see Priming function).

4. At the end of the Reagent 2 cycle, return to the Reagent 2 screen:

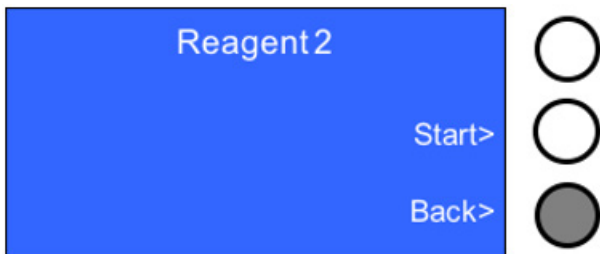

5. Do one of the following:

- Select Back to return to the Main Menu.
- OR
- Select Start to start another Reagent 2 cycle.

The membrane is now ready for reading by the Milliflex® Rapid System 2.0 Detection Tower. To minimize the reduction in the bioluminescent signal, transfer the membrane from the AutoSpray Station to the detection tower within one minute. Place the lid to cover the Milliflex Oasis® Rapid membrane during transfer to minimize evaporation of Reagent 2.

**Important:** After spraying Reagent 2, the wetter areas of the membrane filter can be seen to form concentric rings. This has no effect on the quality of detection or image processing, since sufficient reagent will have been deposited over the entire surface of the membrane filter.

## Membrane Drying function

Use this function to dry membranes one at a time. The membrane moves beneath the Millex™-FG filter in Position 2, where air is blown over the membrane to dry it.

Use Timer mode to set an automatic drying time.

Use Start mode to operate the drying cycle manually. (Press the Stop key to stop drying.)

This function can be used to dry several membranes in succession.

1. Install the membrane holder and place a Milliflex Oasis® membrane filter on the holder.

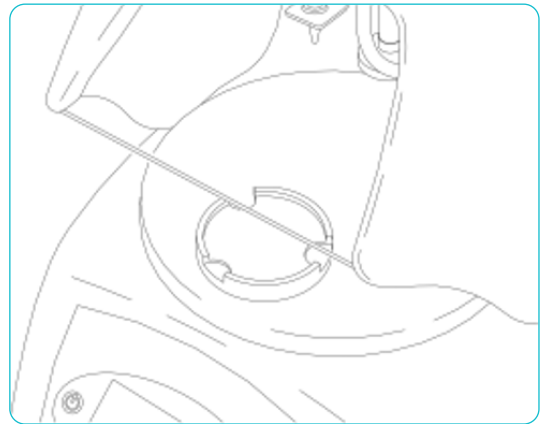

2. Select Membrane Drying from the Main Menu.

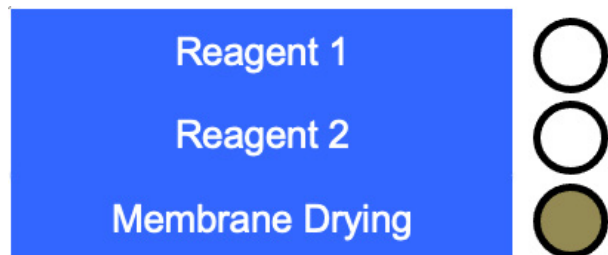

The Membrane Drying screen displays.



3. Do one of the following:

- Select Start to start drying without a programmed drying time (instructions to follow).

OR

- Select Timer to start a drying cycle with a programmed drying time (instructions to follow).

**Note:** Select Back to quit and return to the Main Menu.

To start a membrane drying cycle without a programmed drying time.

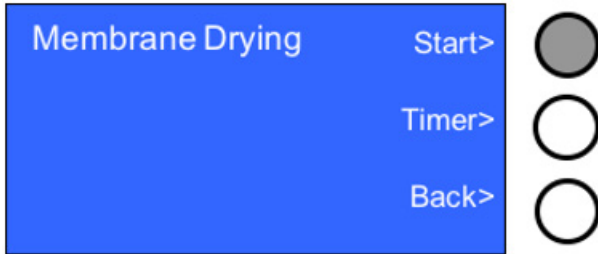

a. Select Start from the Membrane Drying screen.

The membrane spins and goes to Position 2 (see Reagent Dispensing and Drying) where it moves in a short arc back and forth under a stream of filtered air that dries the membrane.

The cycle starts and the elapsed drying time displays on the screen. The screen displays the time in MM:SS.

b. Select Stop to stop drying and return to the Membrane Drying screen.

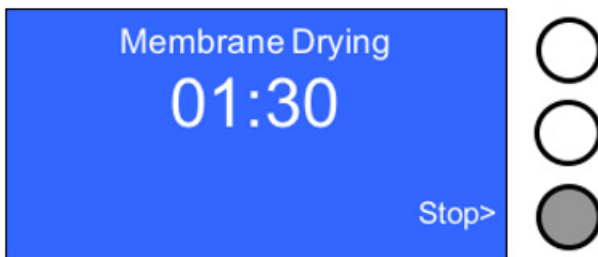

To start a membrane drying cycle with a programmed drying time.

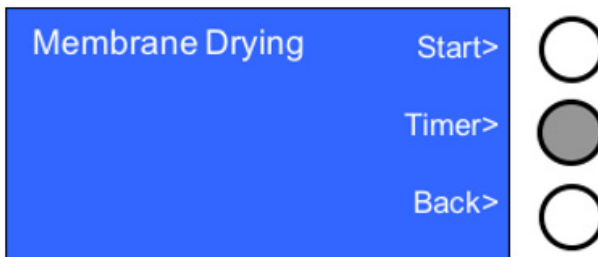



a. Select Timer from the Membrane Drying screen.

The screen displays the previously programmed drying time in MM:SS.

b. Use the + and - keys to change the number of minutes for drying.



c. Press the Up and Down   keys to switch to the seconds. Upon operating one of these keys, the time in minutes stops flashing, and the time in seconds starts to flash.

d. Use the + and - keys to set the number of seconds.

e. Select Start to start the cycle.



The Membrane Drying cycle starts, and a progress bar displays.

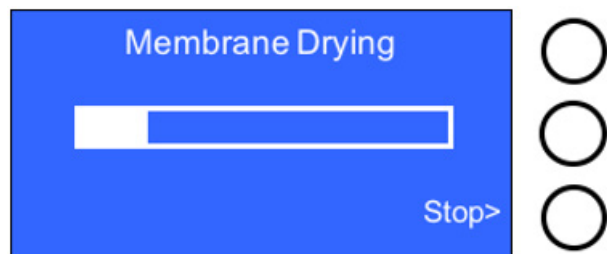

The membrane spins and goes to Position 2 where it moves in a short arc back and forth under a stream of filtered air that dries the membrane until the end of the programmed time.

At the end of the cycle, after the programmed time has elapsed, the Membrane Drying screen displays again.

**Note:** Select Stop to interrupt the current cycle and return to the Membrane Drying screen before the programmed time has elapsed.

4. Do one of the following:

- Select Back from the Membrane Drying screen to quit and return to the Main Menu.

OR

- Select Start to start a new drying cycle without a programmed drying time.

OR

- Select Timer to start a new drying cycle with a programmed drying time.

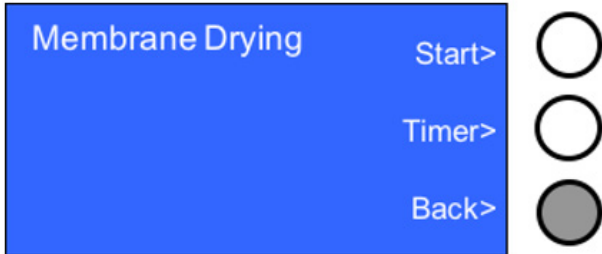

2. Use the Up and Down keys to scroll through the on-screen display (3 lines at a time).

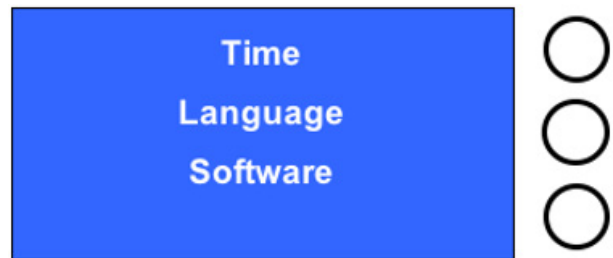
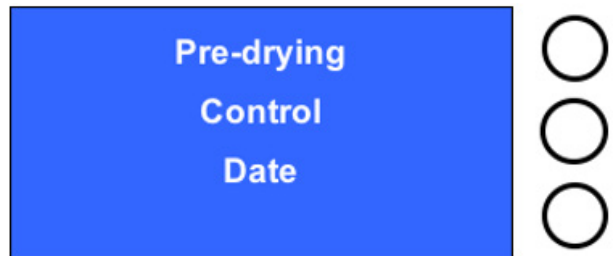
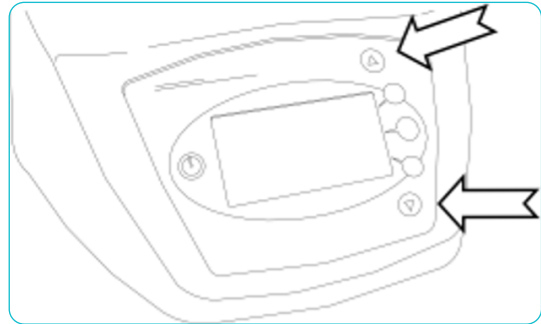

### Menu function

Use this function to access the AutoSpray Station's configuration sub-menus (options and settings).

1. Select Menu from the Main Menu.

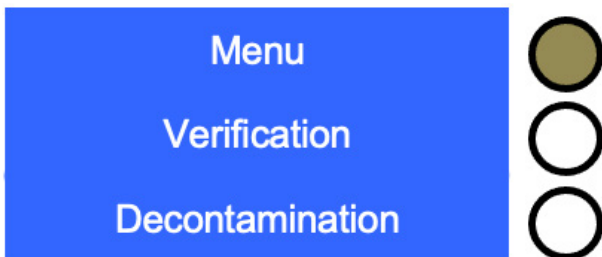

The configuration menu of the Menu function displays.

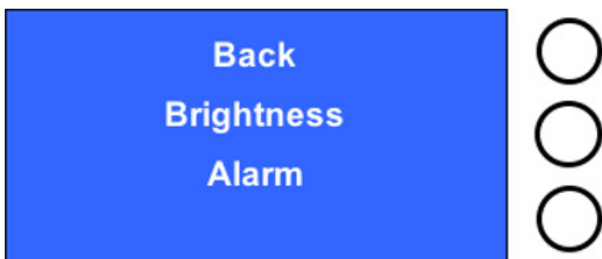

### Adjusting display brightness

1. Select Brightness from the configuration menu.

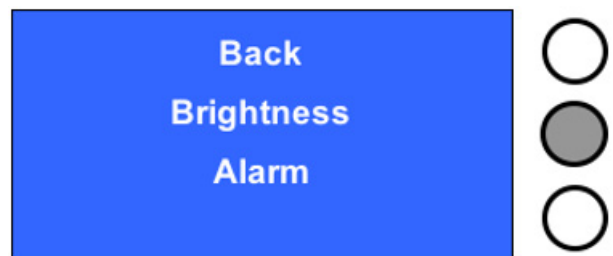

**Note:** Select Back to quit the Menu function and return to the Main Menu.

2. The Brightness screen shows. Use the + and - keys to adjust the brightness of the display.



3. Select OK to confirm the setting and return to the configuration menu.



2. Select ON to enable the alarm and return to the configuration menu.

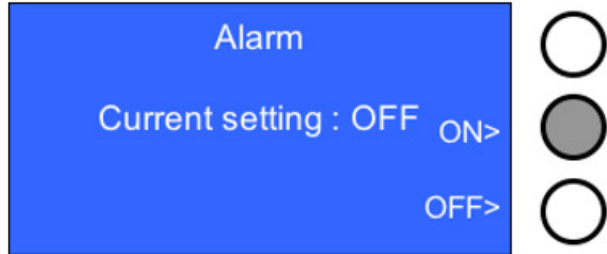

3. Select OFF to disable the alarm and return to the configuration menu.

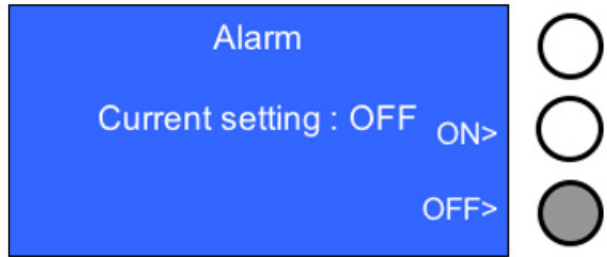

### Turning the alarm on/off

Use this function to enable or disable the audible alarm that signals the end of each cycle.

1. Select Alarm from the configuration menu.

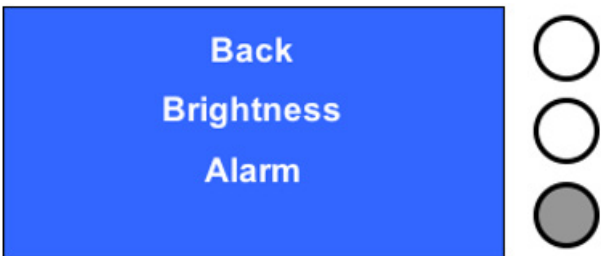

The Alarm screen displays.

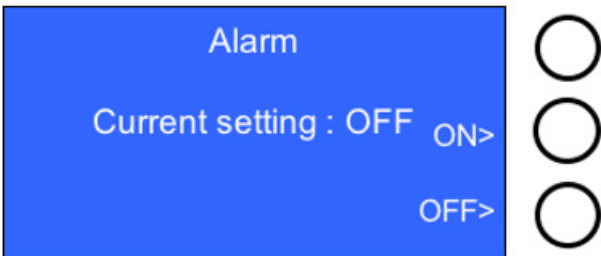

**Note:** The current setting displays.

### Setting pre-drying on/off

Use this function to enable or disable a 5-minute pre-drying period for membrane filters. If the function is enabled, pre-drying is performed before each Autospraying and Reagent 1 Spraying cycle.

1. Select Pre-drying from the configuration menu.

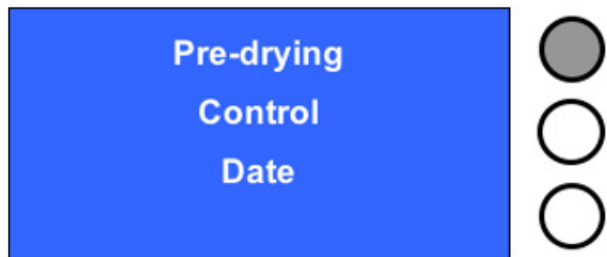

2. The Pre-Drying screen displays.

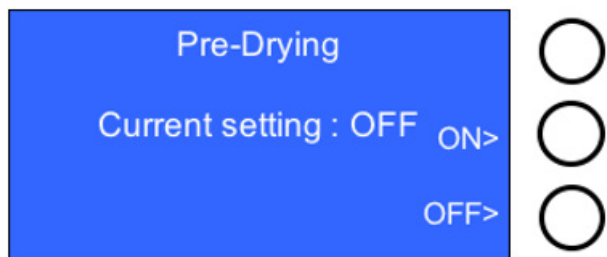

**Note:** The current setting displays.

3. Select ON to enable pre-drying and return to the configuration menu.

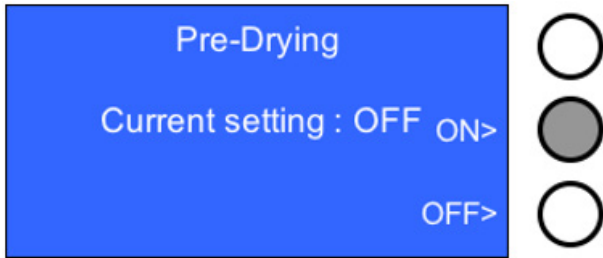

4. Select OFF to disable pre-drying and return to the configuration menu.

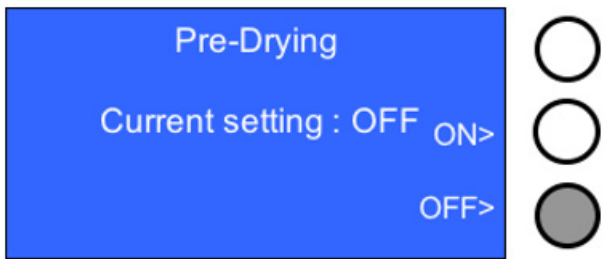

### Setting the date

1. Select Date from the configuration menu.



2. The Date screen displays.

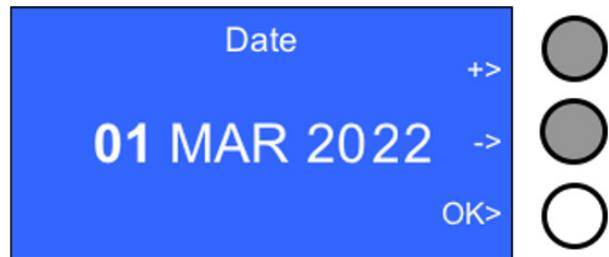



The pre-programmed date displays in DD/MMM/YYYY format.

3. Do one of the following:

- Select OK to return to the configuration menu without changing the date.

OR

- To modify the programmed date, select the parameter (DD, MMM or YYYY) using the scroll keys  . The selected parameter then flashes. Use the + and - keys to adjust the selected parameter. Select OK to confirm the new programmed date and return to the configuration menu.

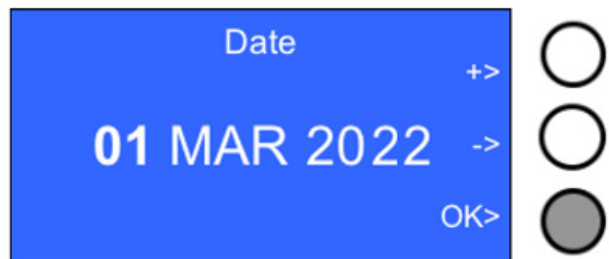

### Tracking the number of spraying cycles

This function displays the number of remaining AutoSpray Station operation cycles before spraying volume re-calibration is necessary (see Volume Adjustment function) and the total number of cycles run since the AutoSpray Station has been in service.

1. Select Control from the configuration menu.

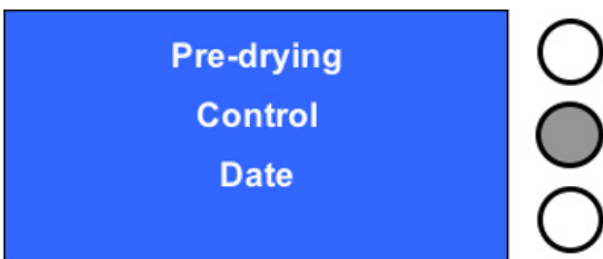

2. The Control screen displays.

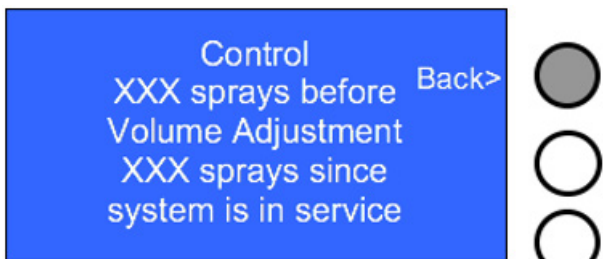

3. Select Back to return to the configuration menu.

## Setting the time

1. Select Time from the configuration menu.

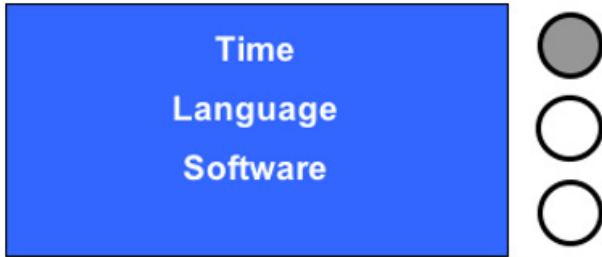

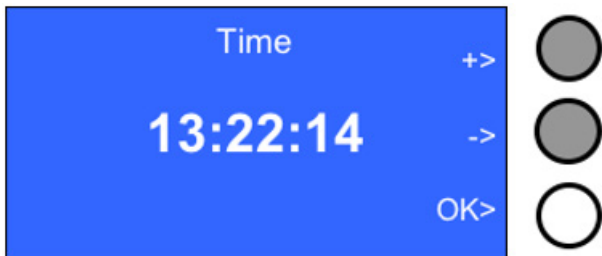

The Time screen displays.



2. Do one of the following:

- Select OK to return to the configuration menu without changing the time.

OR

- To modify the programmed time, select the parameter (hours, minutes, or seconds) using the scroll keys  . The selected parameter then flashes. Use the + and - keys to adjust the selected parameter. Select OK to confirm the new programmed date and return to the configuration menu.

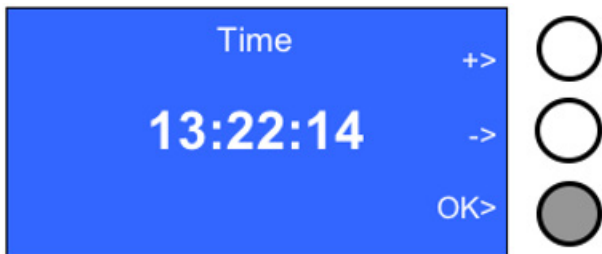

## Displaying the language

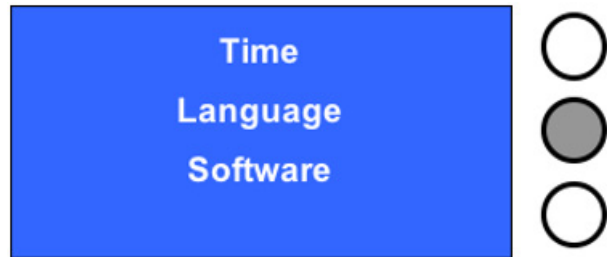

**Note:** This function is not enabled for this version of the software. English is the only language available at this time.

1. Select Language from the configuration menu. The language selection screen displays.
2. Select English to return to the Main Menu.

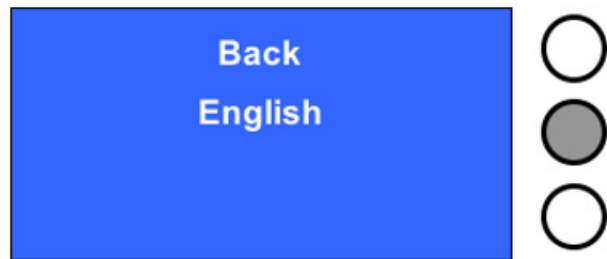

3. Select Back to return to the configuration menu.

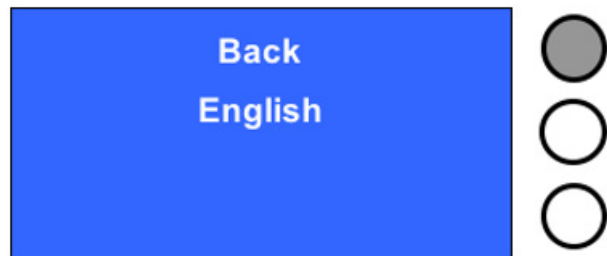

### Checking the software version

1. Select Software from the configuration menu.



The Software screen displays.

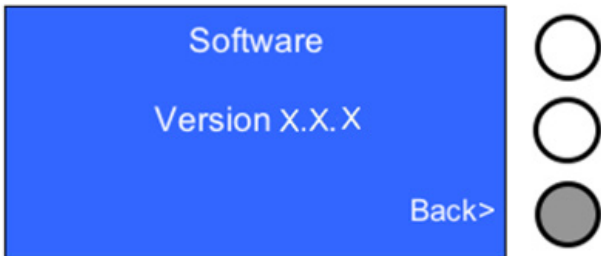

The software version installed in the AutoSpray Station displays.

2. Select Back to return to the configuration menu.

### Returning to the Main Menu

Select Back to quit the configuration menu and return to the Main Menu.

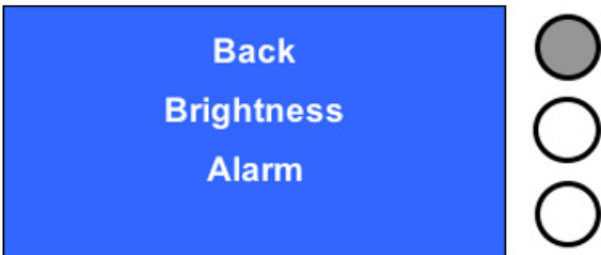

### Verification functions

#### Timer Verification function

Use this function to check if the AutoSpray Station's internal timer for spraying cycles is working with precision.

**Note:** The timer should be tested once a year as part of good laboratory practices.

This procedure requires the use of a calibrated stopwatch.

1. Select Verification from the Main Menu.

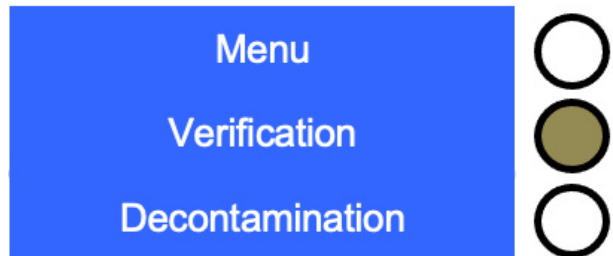

The Verification screen displays.

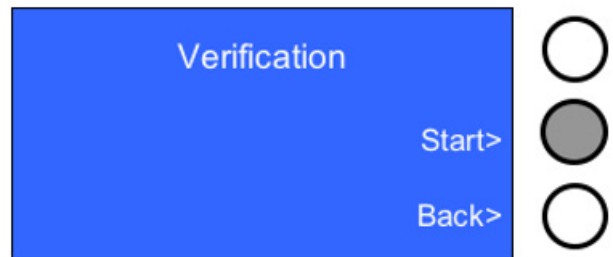

2. Select Start to start a verification cycle.

**Note:** Select Back to quit and return to the Main Menu.

Another Verification screen displays.

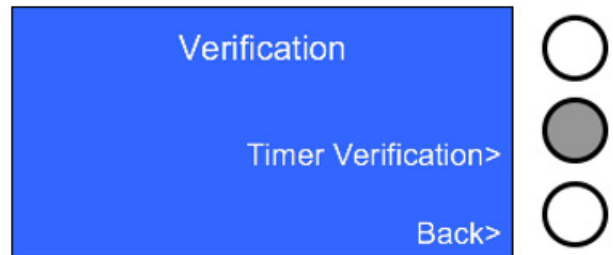

3. Select Timer Verification to verify the spraying time calibration.

**Note:** Select Back to quit and return to the first Verification screen

The Timer Verification screen displays.

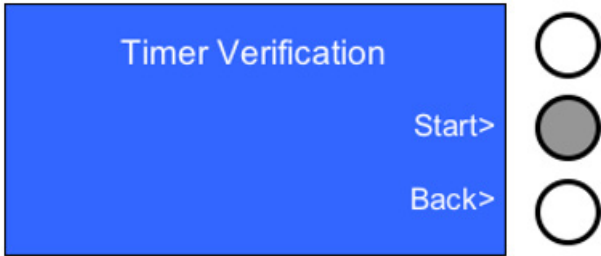

4. Have the stopwatch ready. Select Start to start a Verification cycle.

5. Start the stopwatch as soon as the alarm sounds the beginning of a 10-minute countdown.

The AutoSpray Station starts counting down 10 minutes.

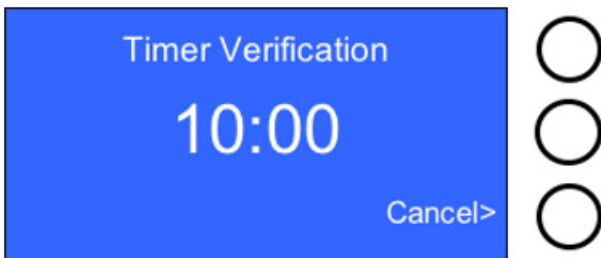

**Note:** Select Cancel to quit the current cycle and return to the first Verification screen.

6. Stop the stopwatch as soon as the alarm sounds the end of the countdown (the verification display then reads 00:01). The display returns to the first Verification screen.

The reading on the calibrated stopwatch must be 10 minutes  $\pm$ 5 seconds. If it falls outside the tolerance, contact technical assistance (see Technical Assistance).

7. Do one of the following:

- Select Back to quit and return to the Main Menu.

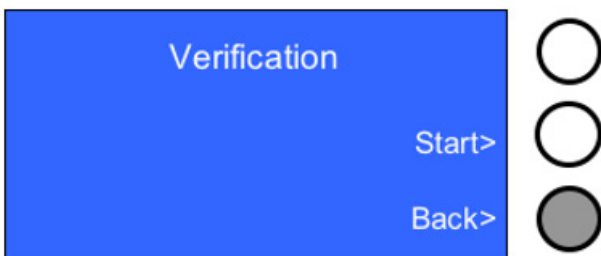

OR

- Select Start to start a new verification cycle.

### Volume Verification function

Verify the volume dispensed by each nebulizer:

- At the time of AutoSpray Station installation
- At least once a month
- After the nebulizers have been cleaned using the nebulizer cleaner (see Nebulizer Maintenance)
- After changing the silicone liquid tubing or after changing the Millex™-FG filters (see Replacing the Silicone Liquid Tubes and Millex™-FG Filters)
- After any other event that may alter the flow of air or liquid into the nebulizers

Use the Autospraying function to verify the volume dispensed. The volume must be measured three times for each nebulizer.

**Caution:** Do not use Reagents 1 or 2 to perform volume verification. This operation must always be performed using the rinsing agent from the Milliflex® Rapid cleaning and decontamination kit (See Spare Parts and Accessories).

1. Prime the two fluid circuits with rinsing agent, one nebulizer at a time. See Priming function.

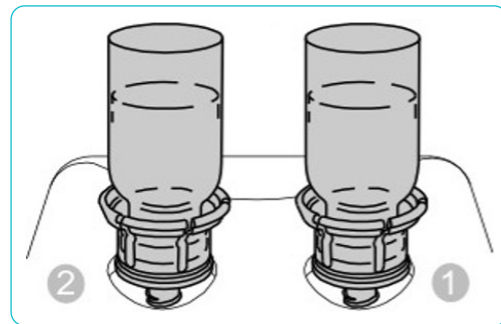

2. Select the Autospraying function from the Main Menu screen:

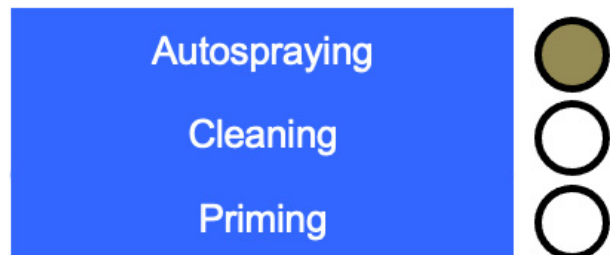

3. Select Autospraying to verify that the nebulizers dispense the appropriate volume for ATP bioluminescence-based total viable count determination (refer to step 5 of this procedure)

4. Weigh a new absorbent pad using a calibrated precision balance (accuracy of 0.001 gram).

**Important:** Evaporation alters the measurement of the volume of liquid deposited onto the pad, so it is important to minimize the loss by placing the balance close to the AutoSpray Station.

5. Use tweezers to hold the pad no more than 5 mm below the nebulizer to be verified, but without direct contact. This will ensure collection of all the liquid sprayed.

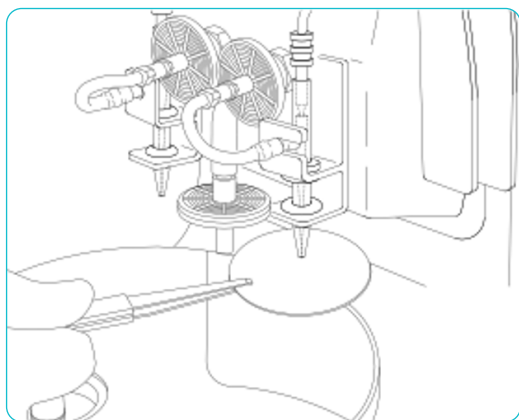

**Note:** PetriSlide™ containers can be used in this step. Their covers protect the sample from evaporation when transferring it from the AutoSpray Station to the balance (see Spare Parts and Accessories).

6. Select Start to run the Autospraying cycle and verify that the nebulizer dispenses the appropriate volume for an ATP bioluminescence-based total viable count determination.

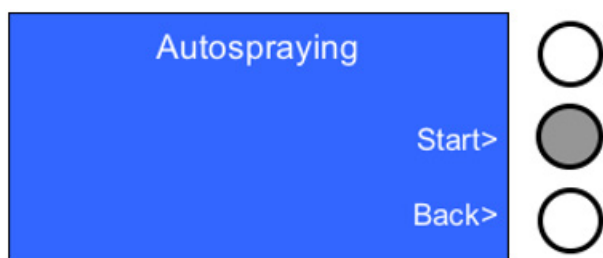

**Note:** When verifying one of the nebulizers, ignore the liquid sprayed from the other nebulizer.

7. Weigh the wetted pad immediately after spraying using a calibrated precision balance (accuracy of 0.001 gram).

**Important:** If the distance between the balance and the AutoSpray Station is more than 3 meters, and PetriSlide™ containers are not being used, place the pad in a closed Petri dish when transferring it from the AutoSpray Station to the balance. Evaporation alters the measurement of the volume of liquid deposited on the pad, so it is important to minimize the loss.

8. Calculate the mass of liquid deposited:

$$\text{Mass of liquid deposited} = \text{Mass of pad after spraying} - \text{Mass of pad before spraying.}$$

**Note:** Density of the liquid is very close to 1. The volume of liquid deposited in  $\mu\text{L}$  is thus equivalent to the mass in mg.

9. Remove the two vials of rinsing agent.

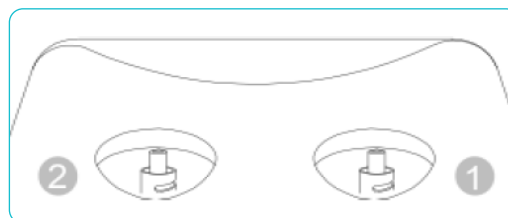

10. Empty the fluid circuits by running a Priming cycle with no vial installed on the AutoSpray Station's Luer ports (see Priming function).

11. Repeat steps 1 to 10 as often as needed to obtain three independent volume values for each nebulizer.

12. For each nebulizer, compare each of the three values with the following tolerances:

- Autospraying, Reagent 1 and Reagent 2 functions:  $25 \leq \text{Vol. } (\mu\text{L}) \leq 45$

13. If one or more of the values measured falls outside these tolerances, run a Volume Adjustment cycle (see Volume Adjustment function) to bring the measured volumes within the above tolerances.

## Decontamination function

Use this function to decontaminate the fluid circuits that come into contact with Reagent 1 or Reagent 2. It requires the decontamination agent contained in the Milliflex® Rapid cleaning and decontamination kit (see Spare Parts and Accessories). A Decontamination cycle consists of four individual cycles, performed in the following order:

- Decontamination Agent cycle
- Air cycle
- Rinsing Agent cycle
- Air cycle

A full Decontamination cycle takes about 25 minutes.

Only one nebulizer can be decontaminated at a time. Run this cycle with one nebulizer and repeat it with the second nebulizer.

Run the Decontamination function under the following circumstances:

- After AutoSpray Station installation
- At least once per week
- Whenever the AutoSpray Station is taken outside its controlled environment
- At power-up of an AutoSpray Station that has not been used for one week or more
- After any servicing or handling of the nebulizers or silicone tubes

**Important:** The decontamination agent must never come into direct contact with Reagent 1 or Reagent 2. Always run a cleaning cycle (see Cleaning function) before and after decontaminating the fluid circuit (except at the time of the initial installation of the Autospray Station) to prevent direct contact between the decontaminating agent and the reagents.

Decontamination may be performed before or after using the AutoSpray Station.

When decontaminating before using the AutoSpray Station, use the following procedure:

- a. Power on the AutoSpray Station and select Skip/continue when prompted by the following messages:

WARNING Cleaning is recommended

WARNING Priming is recommended

- b. Perform the intended Decontamination cycle.
- c. Perform a Cleaning cycle (see Cleaning function).

- d. Use the instrument (see the following: Autospraying function, Priming function, Reagent 1 Spraying function or Reagent 2 Spraying function).
- e. Perform a Cleaning cycle during the AutoSpray Station shutdown sequence (see Cleaning function).

When decontaminating after using the AutoSpray Station, use the following procedure:

- a. Power on the AutoSpray Station.
- b. Perform a Cleaning cycle (see Cleaning function).
- c. Use the system (see the following: Autospraying function, Priming function, Reagent 1 Spraying function or Reagent 2 Spraying function).
- d. Perform a Cleaning cycle (see Cleaning function).
- e. Perform the intended Decontamination cycle.
- f. Turn off the AutoSpray Station. Select Skip/continue to ignore the WARNING "Cleaning is recommended" message.

It will be essential to run a Cleaning cycle the next time the AutoSpray Station is powered up.

To decontaminate the system:

1. Select the Decontamination function from the Main Menu.

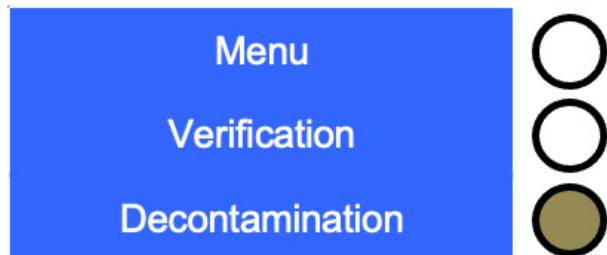

The Decontamination screen displays.

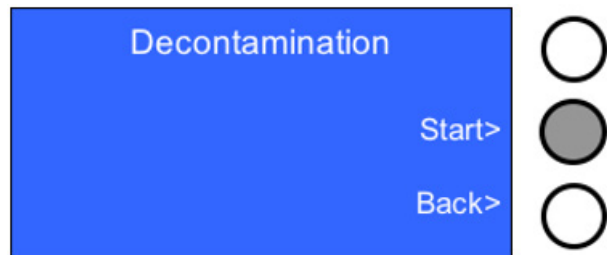

2. Select Start to start a Decontamination cycle.

**Note:** Select Back to quit and return to the Main Menu.

Another Decontamination screen displays.

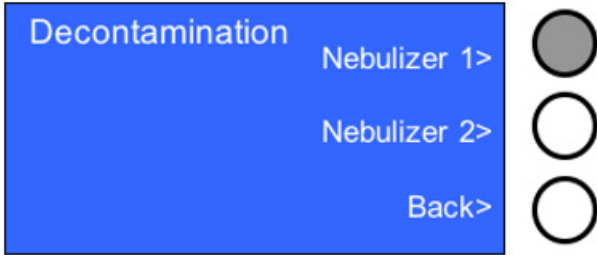

3. Do one of the following:

- Select Nebulizer 1 to start the Nebulizer 1 (on the right) Decontamination cycle.

OR

- Select Nebulizer 2 to start the Nebulizer 2 (on the left) Decontamination cycle.

**Note:** The cycle is identical for both nebulizers. The procedure described HERE is for Nebulizer 1. Use the same procedure to decontaminate Nebulizer 2 immediately after decontaminating Nebulizer 1.

Select Back to quit and return to the Decontamination screen.

The Decontamination Agent Nebulizer 1 screen displays.

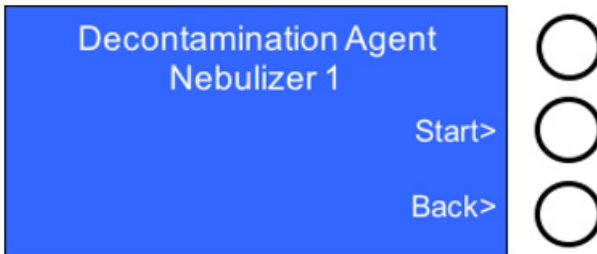

4. Install the vial of Decontamination Agent on the nebulizer to be decontaminated.

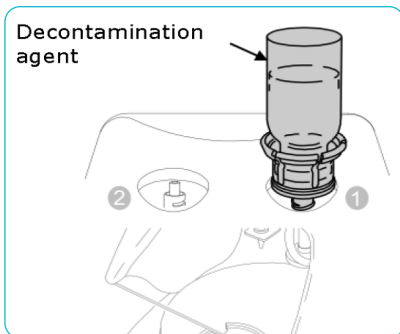

5. Fit 3 pads on top of each other to the absorbent pad holder.

6. Select Start from the Decontamination Agent Nebulizer 1 screen to start the decontamination cycle.

**Note:** Select Back to quit and return to the Decontamination screen.

The Decontamination Agent Nebulizer 1 cycle starts, and a progress bar displays

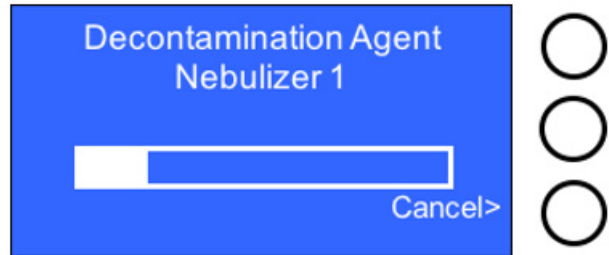

The turntable moves the pad holder under Nebulizer 1 and sprays decontaminating fluid onto the absorbent pad for a short time. The spraying stops, and the pinch valve closes to allow sufficient contact time for thorough decontamination. The nebulizer then resumes spraying the decontamination agent. When the spraying stops, the pinch valve closes and the turntable moves the pad holder back to the starting Position 0.

**Note:** The pad holder remains under the nebulizer for the full contact time.

Select Cancel to stop the current cycle and return to the Decontamination Agent Nebulizer 1 screen.

At the end of the Decontamination Agent Nebulizer 1 cycle, the Air Nebulizer 1 screen displays.

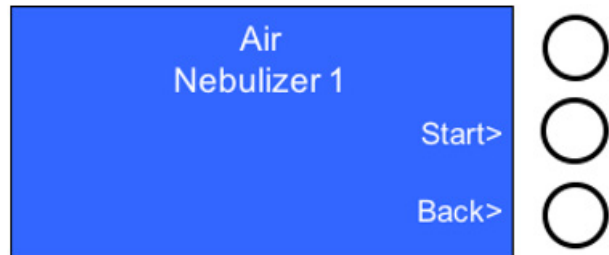

7. Remove the vial of decontamination agent.

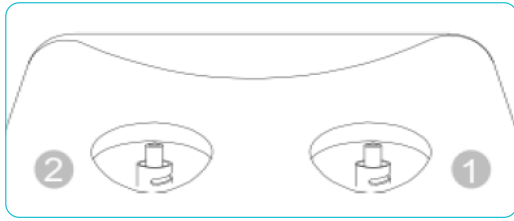

8. Select Start from the Air Nebulizer 1 screen.

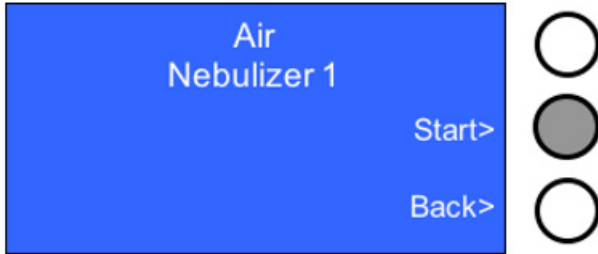

**Note:** Select Back to quit and return to the Decontamination Agent Nebulizer 1 screen.

The Air cycle starts, and a progress bar displays.

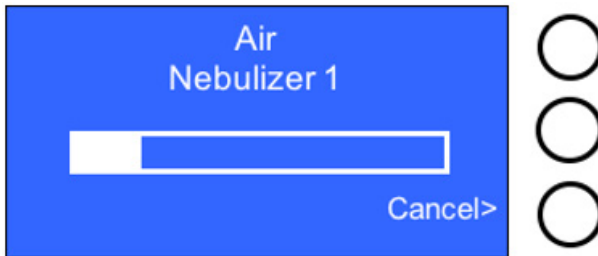

The pad holder moves under the nebulizer, and the air purges the fluid circuit. At the end of this step, the turntable moves the pad holder back to the start position.

**Note:** Select Cancel to stop the current cycle and return to the Air Nebulizer 1 screen.

At the end of the air cycle, the Rinsing Agent Nebulizer 1 screen displays.

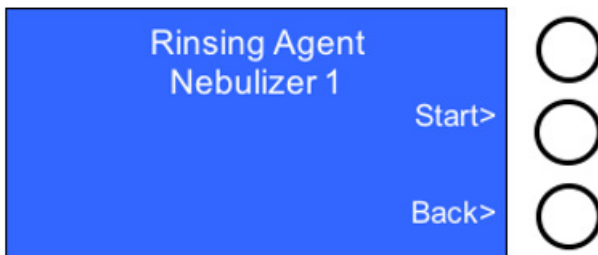

9. Install a vial of rinsing agent on the nebulizer to be rinsed.

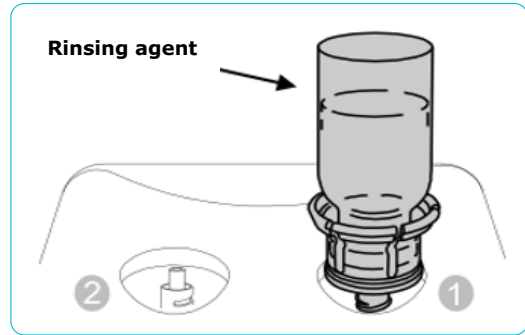

10. Select Start from the Rinsing Agent Nebulizer 1 screen to start a rinsing cycle.

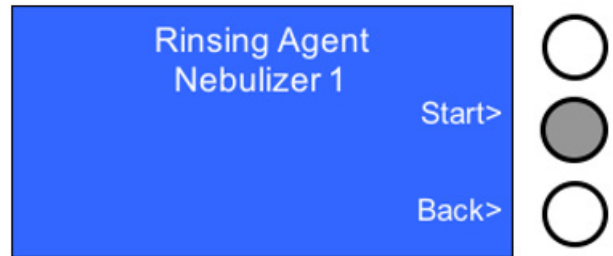

**Note:** Select Back to quit and return to the Air Nebulizer 1 screen.

The Rinsing Agent Nebulizer 1 cycle starts and a progress bar displays.

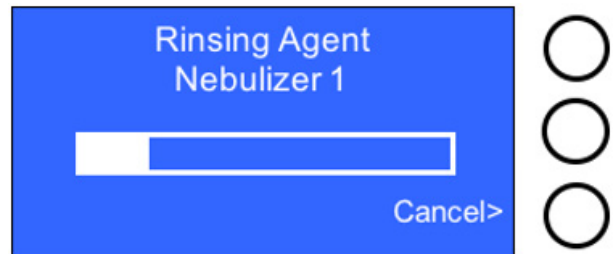

The turntable moves the pad holder under the nebulizer. Some rinsing agent is sprayed onto the pad and then stops. After a sufficiently long contact time to ensure thorough rinsing effectiveness, the rinsing agent continues to rinse the nebulizer. The liquid is soaked up by the absorbent pad.

**Note:** The pad holder remains under the nebulizer being rinsed for the entire contact time.

At the beginning of this cycle, the pinch valve opens for a very short period, allowing a little rinsing agent to enter the nebulizer outlet (inside as well as outside the capillary tube). The liquid is eliminated from the outside of the capillary tube when spraying resumes.

Select Cancel to stop the current cycle and return to the Rinsing Agent Nebulizer 1 screen.

At the end of the Rinsing Agent Nebulizer 1 cycle, the Air Nebulizer 1 screen displays.

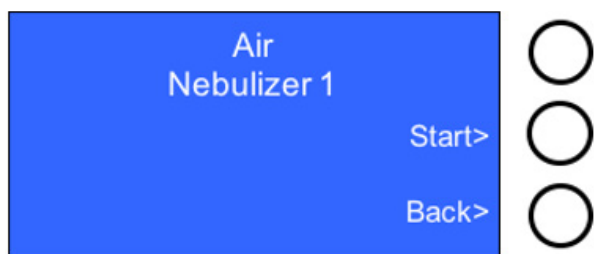

11. Remove the vial of rinsing agent.

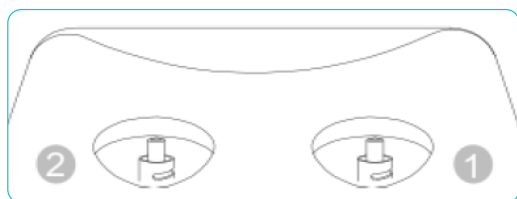

12. Select Start from the Air Nebulizer 1 screen.

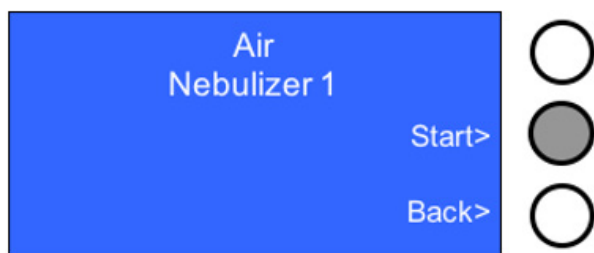

**Note:** Select Back to quit and return to the Rinsing Agent Nebulizer 1 screen.

The second Air cycle starts and a progress bar displays.

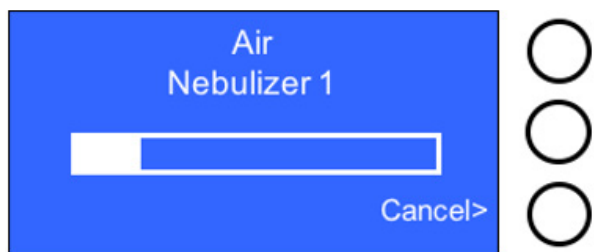

The air purges the fluid circuit.

**Note:** Select Cancel to stop the current cycle and return to the Air Nebulizer 1 screen.

At the end of the Air cycle, the Decontamination screen displays.

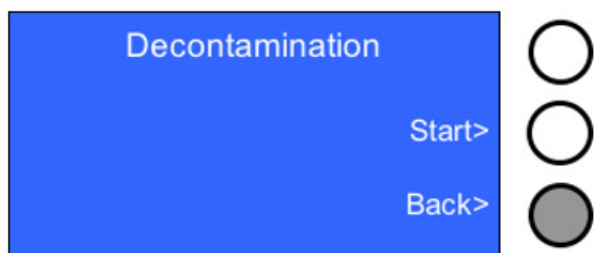

13. Do one of the following:

- Select Back to quit and return to the Main Menu.
- OR
- Select Start to start a new Decontamination cycle (see step 3 of the procedure), for example to decontaminate the other nebulizer.

Autoclave (121 °C for 15 minutes or 134 °C for 5 minutes) the stainless steel caps every time the AutoSpray Station is decontaminated, so that they are clean when the AutoSpray Station Luer ports are decontaminated.

### Volume Adjustment function

The Milliflex® Rapid System 2.0 AutoSpray Station is calibrated to deliver a volume of 35 µL ±10 µL per membrane, using the Reagent 1 Spraying function or the Reagent 2 Spraying function. Use the Volume Adjustment function to reset the volumes sprayed by the nebulizers and bring them to between 25 µL and 45 µL.

**Note:** The volume dispensed by the nebulizers may vary if the cleaning procedure is not properly followed (see Cleaning function).

Perform this operation under the following conditions:

- After any volume verification operation that produces results falling outside tolerance (see Volume Verification function).
- Whenever a new nebulizer is installed (see Replacing a Nebulizer)
- Every 5,000 spraying cycles or every 12 months, whichever occurs first. When the number of cycles exceeds the figure, the following warning message displays:

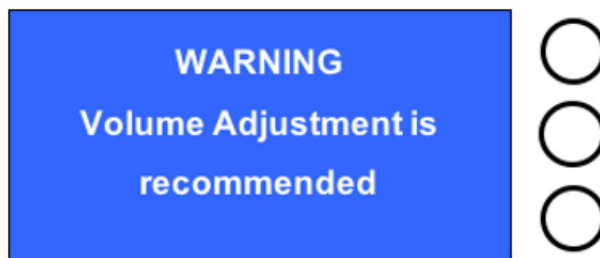

**Important:** Do not use Reagent 1 or Reagent 2 when performing volume verification. This operation must always be performed using the rinsing agent from the Milliflex® Rapid cleaning and decontamination kit (see Spare Parts and Accessories).

Materials needed:

- Five absorbent pads or five PetriSlide™ containers with pads (see Spare Parts and Accessories) per nebulizer. Label the pads or containers 1, 2, 3, 4, and 5.
- A calibrated balance accurate to 0.001 g
- Rinsing reagent from the Milliflex® Rapid cleaning and decontamination kit (see Spare Parts and Accessories).

**Note:** PetriSlide™ containers are covered, which protects the sample from evaporating when transferring it from the AutoSpray Station to the balance (see Spare Parts and Accessories).

This is how to perform volume adjustment:

1. Select Volume Adjustment from the Main Menu screen.

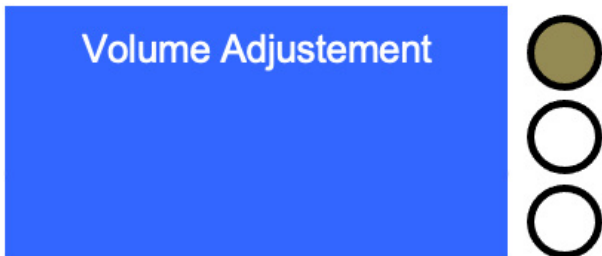

The Volume Adjustment screen displays.

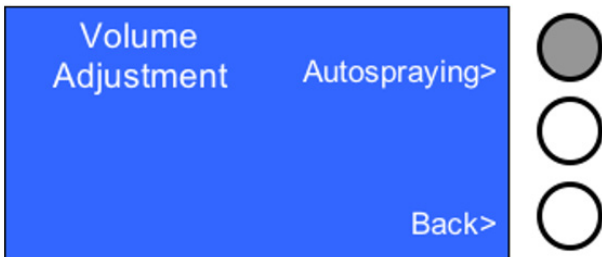

2. Select Autospraying to adjust the volume dispensed by the nebulizers when using the Autospraying, Reagent 1 (for Nebulizer 1) or Reagent 2 (for Nebulizer 2) spraying functions.

**Note:** Select Back to quit and return to the Main Menu.

Only the procedure for the Autospraying function is described below.

The Volume Adjustment Autospraying screen displays.

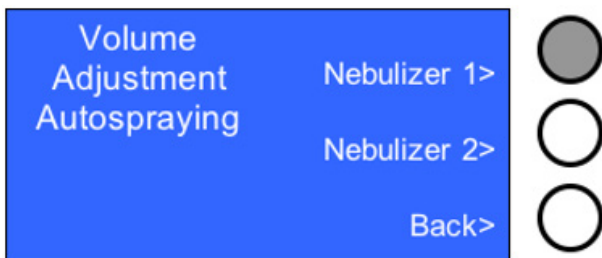

3. Do one of the following:

- Select Nebulizer 1 to reset the volume dispensed by nebulizer 1
- OR
- Select Nebulizer 2 to reset the volume dispensed by nebulizer 2.

**Note:** Select Back to quit and return to the Volume Adjustment screen.

The cycle is identical for both nebulizers. Only the procedure for Nebulizer 1 is described below.

The balance must be located close to the AutoSpray Station to prevent any evaporation, which could alter the measurement of the volume of liquid deposited on the pad.

The Volume Adjustment Autospraying Nebulizer 1 Priming Rinsing Agent screen displays.

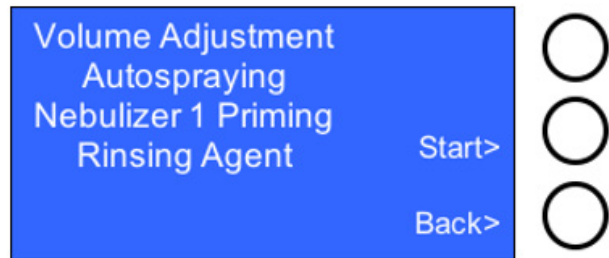

4. Install a vial of rinsing agent (white label) on Nebulizer 1.

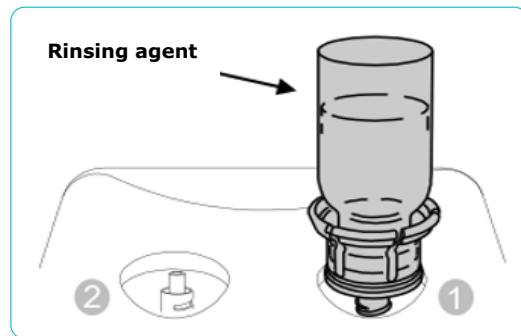

5. Select Start from the Volume Adjustment Autospraying Nebulizer 1 Priming Rinsing Agent screen.

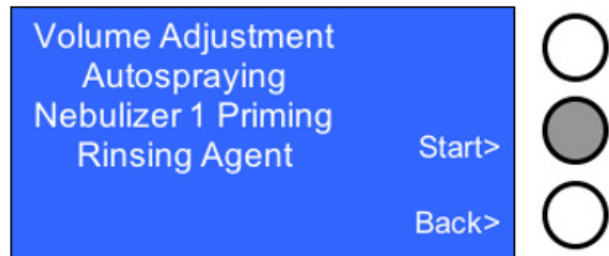

**Note:** Select Back to quit and return to the Volume Adjustment Autospraying screen.

The volume adjustment Autospraying Nebulizer 1 Priming cycle starts and a progress bar displays.

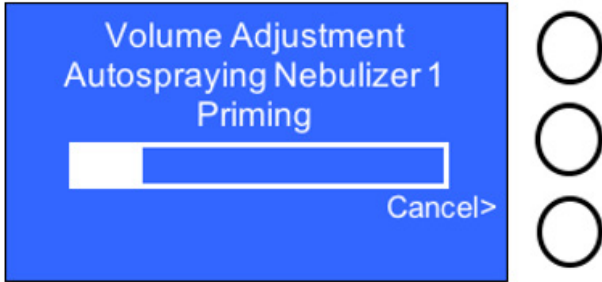

The turntable moves the pad holder under the nebulizer and sprays rinsing agent onto the pad. The fluid circuit is primed with Rinsing Agent.

**Note:** Select Cancel to stop the current cycle and return to the Volume Adjustment Autospraying Nebulizer 1 Priming Rinsing Agent screen.

At the end of the Priming cycle, the Volume Adjustment Autospraying Nebulizer 1 Test 1 screen displays.

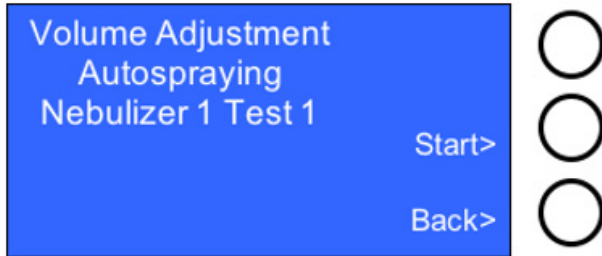

6. Weigh each of the five unused pads using a calibrated precision balance (accuracy of 0.001 gram).
7. Use tweezers to place the pad within 5 mm of the end of the nebulizer to be verified, but without direct contact. This will ensure collection of all the liquid sprayed.

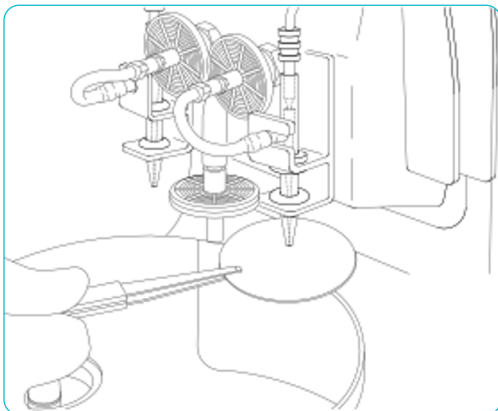

8. Select Start from the Volume Adjustment Autospraying Nebulizer 1 Test 1 screen to start the first test.

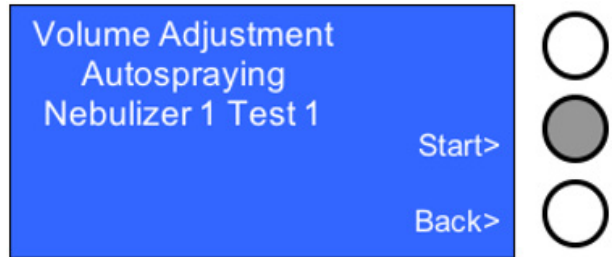

**Note:** Select Back to quit and return to the Volume Adjustment Autospraying Nebulizer 1 Priming Rinsing Agent screen.

The test 1 cycle starts, and a progress bar displays.

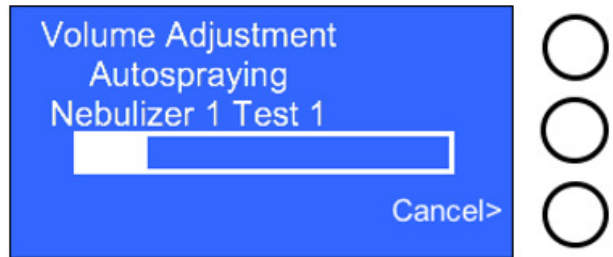

The turntable moves the pad holder under the nebulizer and sprays the rinsing agent. The liquid is soaked up by the pre-weighed pad.

**Note:** Select Cancel to stop the current cycle and return to the Volume Adjustment Autospraying Nebulizer 1 Test 1 screen.

9. Weigh the pad immediately after spraying.

**Important:** If the distance between the balance and the AutoSpray Station is more than 3 meters, place the pad in a closed Petri dish or PetriSlide™ container when transferring it from the AutoSpray Station to the balance. Evaporation alters the measurement of the volume of liquid deposited on the pad, so it is important to minimize the loss by placing the balance close to the AutoSpray Station.

10. Calculate the mass of liquid deposited:

$$\text{Mass of liquid deposited} = \text{Mass of pad after spraying} - \text{Mass of pad before spraying}$$

**Note:** Density of the liquid is very close to 1. The volume of liquid deposited in  $\mu\text{L}$  is thus equivalent to the mass in mg.

At the end of the test 1 cycle, the Volume Adjustment Autospraying Nebulizer 1 Test 2 screen displays.

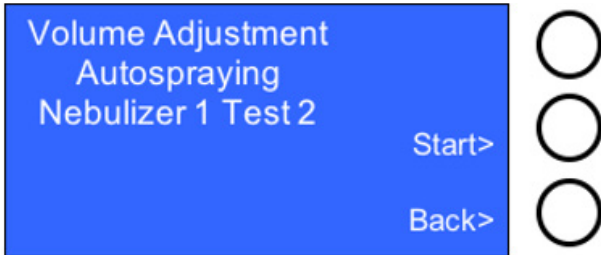

11. Repeat step 7.

12. Select Start from the Volume Adjustment Autospraying Nebulizer 1 Test 2 screen to start the second test.

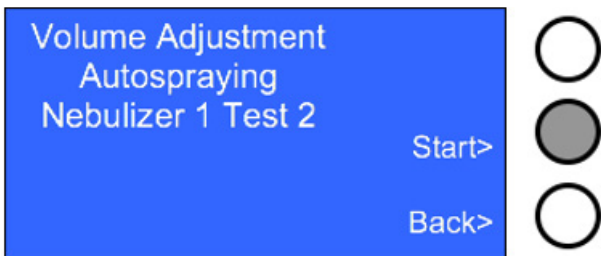

**Note:** Select Back to quit and return to the Volume Adjustment Autospraying Nebulizer 1 Test 1 screen.

The test 2 cycle starts and a progress bar displays.

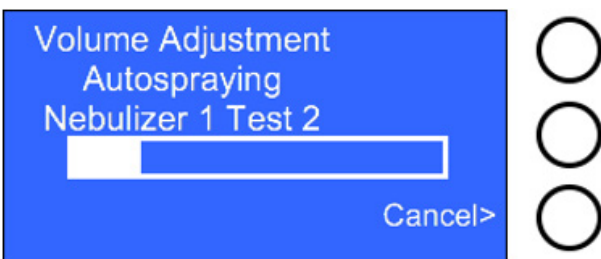

The liquid sprayed by the nebulizer is soaked up by the pad.

**Note:** Select Cancel to stop the current cycle and return to the Volume Adjustment Autospraying Nebulizer 1 Test 2 screen.

13. Repeat steps 9 and 10.

14. Following the instructions on the display, perform three more tests using the same protocol (Test 3, Test 4, and Test 5).

15. Calculate the mean of all 5 test values.

At the end of the Test 5 cycle, the "Volume Adjustment Autospraying Nebulizer 1 Enter sprayed weight" screen displays.

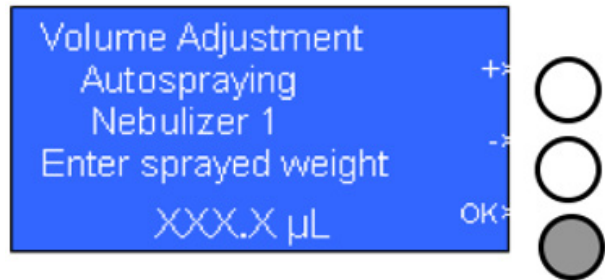

The average value (mean of 5) must be entered in the XXX.X  $\mu\text{L}$  format:

- Select the digit using the scroll keys. The selected digit flashes.
- Adjust the selected digit using the + and - keys.
- Move to the next digit using the scroll key.
- Once the correct volume has been entered, Select OK to enter the value into the AutoSpray Station software.

**Note:** The AutoSpray Station software recalculates the spraying time for the nebulizer so that the deposited volume is  $35 \mu\text{L} \pm 10 \mu\text{L}$  when using the Autospraying, Reagent 1 (for Nebulizer 1), and Reagent 2 (for Nebulizer 2) functions. The instrument realizes the change in spraying time by automatically adjusting the time that the pinch valve remains opened.

The "Volume Adjustment Autospraying Nebulizer 1 Save new adjustment?" screen displays.

16. Do one of the following:

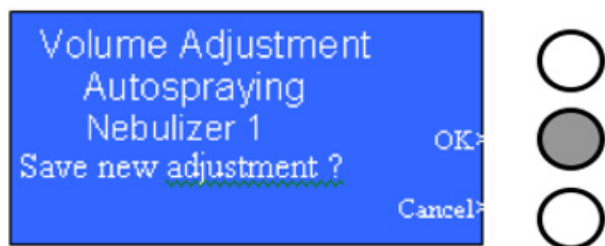

- Select OK to save the new adjustment.

OR

- Select Cancel to not save the adjustment and return to the Volume Adjustment Autospraying screen and start another Volume Adjustment cycle (see step 3 of this procedure).

**Note:** If the error message "Volume Adjustment Autospraying Nebulizer ERROR Please contact Millipore" displays, refer to Troubleshooting. Select OK to exit this error message.



At the end of the Air cycle, the Volume Adjustment screen displays.

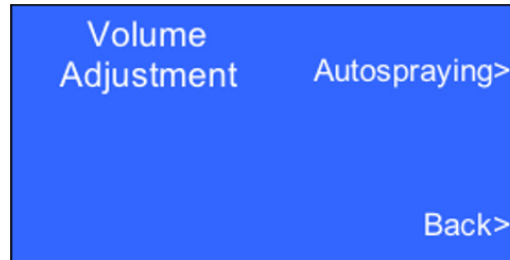

The Air Nebulizer 1 screen displays.

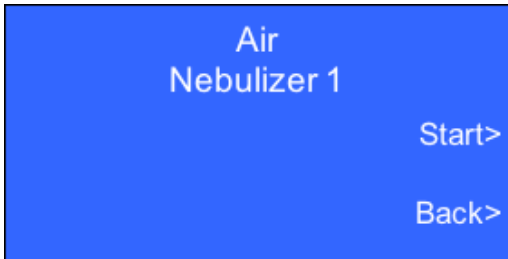

19. Select Back to return to the Main Menu.

**Note:** Select Autospraying to start another volume adjustment cycle (see step 2 of this procedure), for example to adjust the spraying volume of the other nebulizer (Nebulizer 2). This is conducted the same way as for Nebulizer 1.

17. Remove the vial of rinsing agent.

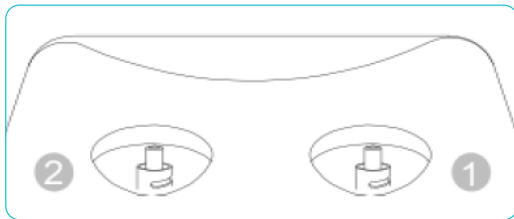

### Warning Message: Volume Adjustment is recommended

When the number of cycles run exceeds the total number of recommended cycles prior to Volume adjustment, a warning message displays.



18. Select Start from the Air Nebulizer 1 screen.

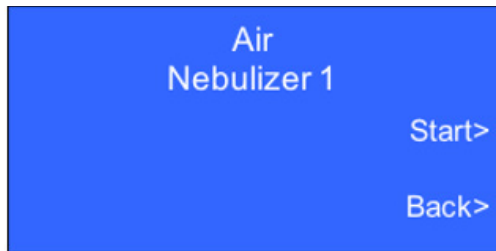

Run the Volume Adjustment Function (see Volume Adjustment Function.)

**Note:** The recommended number of spraying cycles between Volume Adjustments is 5,000. Contact Technical assistance every 5,000 cycles or every 12 months (whichever occurs first) to arrange for a full service of the AutoSpray Station.

**Note:** Select Back to quit and return to the Volume Adjustment Autospraying screen.

The Air cycle starts, and a progress bar displays.

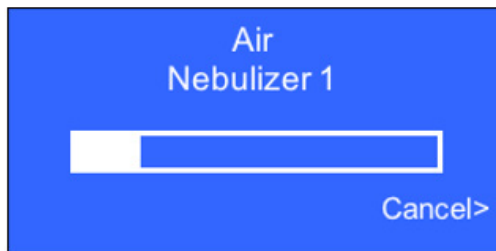

The air purges the fluid circuit.

**Note:** Select Cancel to stop the current cycle and return to the Air Nebulizer 1 screen.

## Shutdown

Shut down the AutoSpray Station at the end of each day to prevent any premature wear or any distortion of the silicone liquid tubes. Shutting down the AutoSpray Station opens the pinch valves.

**Note:** If the AutoSpray Station is not shut down, the instrument goes into sleep mode (see Letting the System Go into Sleep Mode). This opens the pinch valves to protect the silicone liquid tubes. The system goes into sleep mode when no key has been pressed on the AutoSpray Station for one hour after the Air steps of the Cleaning and Decontamination functions (see Precautions for Silicone Liquid Tubes).

Before shutting down or disconnecting the AutoSpray Station, remove the vials from the Luer ports to prevent liquid from leaking out.

**Important:** Clean the AutoSpray Station before shutdown (see Cleaning function).

This is how to shut down the AutoSpray Station:

1. Press the On/Off key on the left of the display.

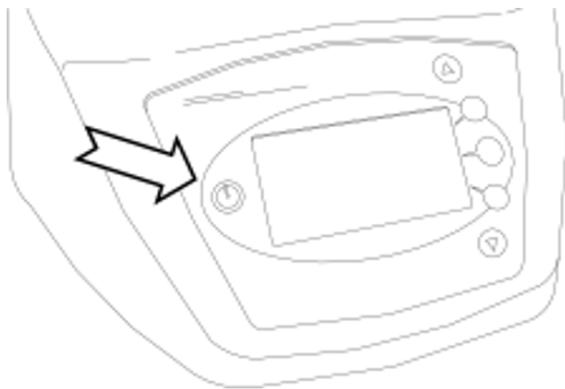

The screen then prompts the operator to run the Cleaning cycle.

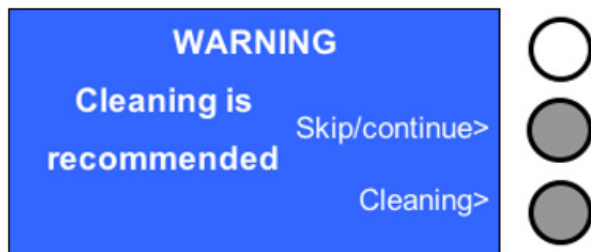

2. Do one of the following:

- Select Skip/continue (or press the On/Off key again) to ignore the warning and shut down the AutoSpray Station.

OR

- Select Cleaning to shut down the AutoSpray Station after a Cleaning cycle (see Cleaning function).

**Note:** Remove all liquid vials and purge the system with air before shutting down to prevent liquid from dripping.

## Maintenance

Before using the AutoSpray Station, carefully disinfect all the external surfaces (especially the turntable, stainless steel caps, Luer ports, membrane holder and pad holder) using a wipe soaked in 70% alcohol.

Never use a liquid, aerosol cleaner, solvents, or abrasives capable of damaging the surfaces of the AutoSpray Station.

Stainless steel parts (caps, membrane holder and pad holder) may be autoclaved. The requirement is 121 °C for 15 minutes or 134 °C for 5 minutes.

### Maintenance schedule

Follow this maintenance schedule when the system is generally in use.

Daily	Disinfect all surfaces with a wipe soaked in 70% alcohol: turntable, stainless steel caps, Luer ports, membrane holder, and pad holder.  Perform a Cleaning cycle with a Milliflex® Rapid cleaning and decontamination kit (see Spare Parts and Accessories) before and after use (see Cleaning function).
Weekly	Remove the protective front cover by lifting it vertically and disinfect the entire stainless steel structure of the AutoSpray Station with a wipe soaked in 70% alcohol as well as the inside and the outside of the cover itself. Re-install the cover.  Autoclave (121 °C for 15 minutes or 134 °C for 5 minutes) the stainless steel caps, membrane holder and pad holder so that they are clean when the AutoSpray Station Luer ports are decontaminated.  Execute a Decontamination cycle (see Decontamination function) with a Milliflex® Rapid cleaning and decontamination kit (see Spare Parts and Accessories).
Monthly	Perform a Volume Verification cycle (see Volume Verification function). If results fall outside the tolerance range, perform a Volume Adjustment cycle (see Volume Adjustment function).
Every six months	Change the silicone liquid tubing and Millex™-FG filters (see Replacing the Silicone Liquid Tubes and Millex™-FG Filters). Follow these operations by a Decontamination cycle (see Decontamination function), a Cleaning cycle (see Cleaning function), and a Volume Verification cycle (see Volume Verification function). If results fall outside the tolerance range, perform a Volume Adjustment cycle (see Volume Adjustment function).
Annually or every 5,000 spraying cycles (whatever comes first)	General preventative maintenance should be carried out by a technical representative (see Technical Assistance).

## Preventive maintenance

### Replacing the silicone liquid tubes and Millex™-FG filters

Replace the silicone liquid tubes and Millex™-FG filters every six months. Also replace Millex™-FG filters after decontamination of the nebulizer air inlet circuits or when installing a replacement nebulizer (see Replacing a Nebulizer). Spare silicone liquid tubes and Millex™-FG filters are provided in the box of accessories (also see Spare Parts and Accessories).

**Important:** Remove the vials before proceeding.

The circuits must be cleaned to remove residual liquid.

The instrument must be turned off and disconnected from the power supply.

1. Do one of the following:

- Select Skip/continue (or press the On/Off key again) to ignore the warning and shut down the AutoSpray Station,

OR

- Select Cleaning to shut down the AutoSpray Station after a Cleaning cycle (see Cleaning function).
- Disconnect the electrical power supply.

2. Remove the protective front cover by lifting it vertically. Wear gloves.



3. Replace the Millex™-FG filters.

- a. Disconnect the air inlet tube from the Millex™-FG filters.

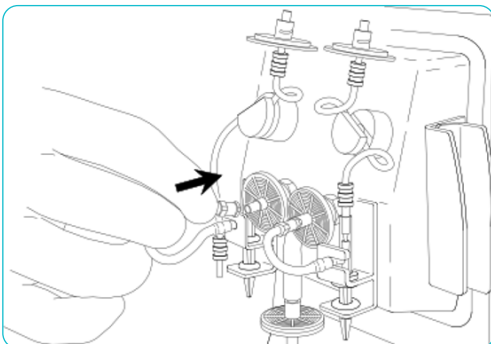

- b. Replace the Millex™-FG filters.

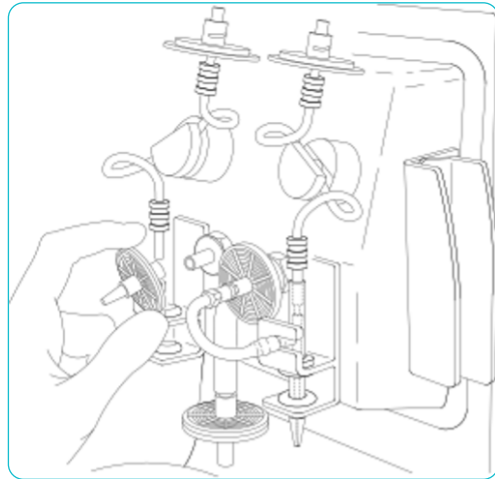

- c. Re-connect the air inlet tube to the outlet (male) end of the Millex™-FG filter.

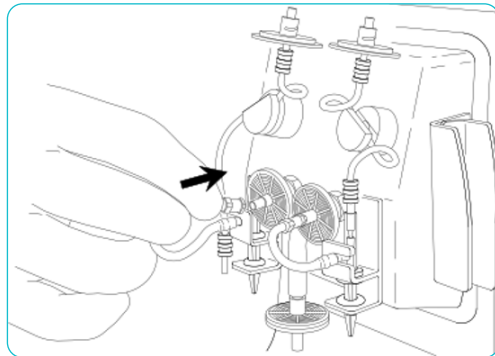

- d. Replace the Millex™-FG filter on the drying outlet.

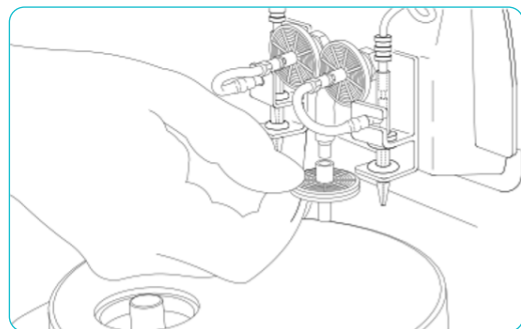

4. Remove the silicone liquid tubes:

**Note:** Do not remove the nebulizers from the nebulizer holders during this operation.

- a. Remove the tube from the pinch valve by holding it either side of the pinch valve and lifting it vertically.

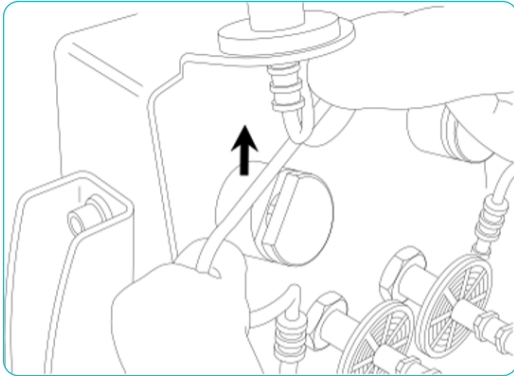

- b. Remove the upper end of the silicone liquid tube from the AutoSpray Station Luer port outlet.

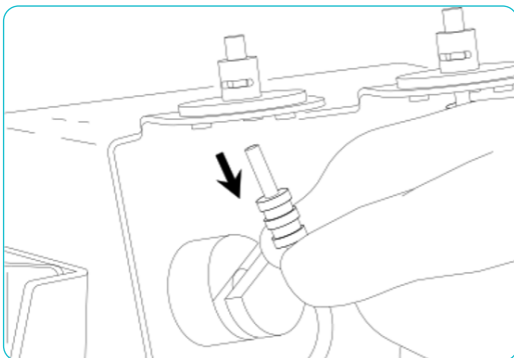

- c. Remove the lower end of the silicone tube for liquid from the nebulizer inlet port.

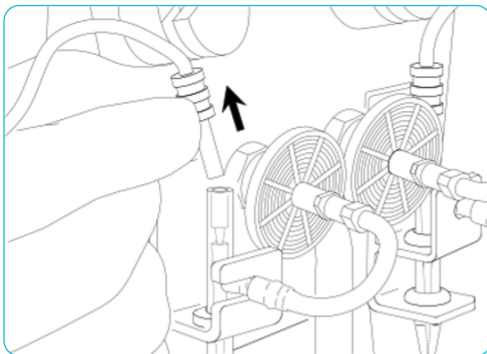

5. Install new silicone liquid fluid tubes:

- a. Insert the tube into the pinch valve by holding it either side of the pinch valve and pushing it downwards as far as it will go.

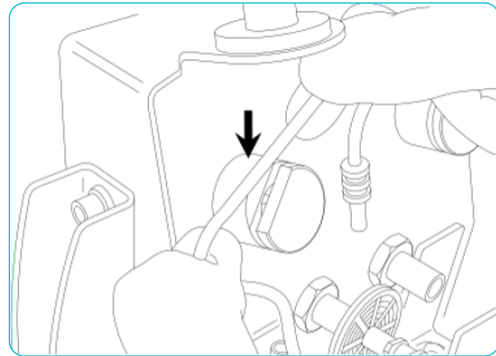

**Note:** Insert the tube at its midpoint so that equal lengths remain upstream and downstream of the pinch valve.

- b. Insert the upper end of the silicone tube as far as it will go into the AutoSpray Station Luer port outlet. The tube must form a loop between the pinch valve and the Luer port outlet. This section of the tube must not be kinked or pinched.

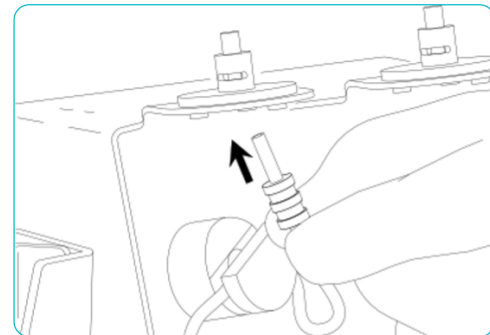

- c. Insert the end of the lower section of the silicone tube for liquids as far as it will go into the nebulizer inlet port. The tube must form a loop between the pinch valve and the nebulizer inlet port. This portion of the tube must not be kinked or pinched.

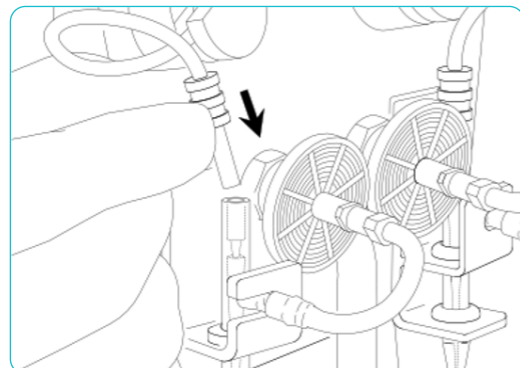

- Fit the protective front cover vertically, ensuring that the guides fit properly into the guide grooves.

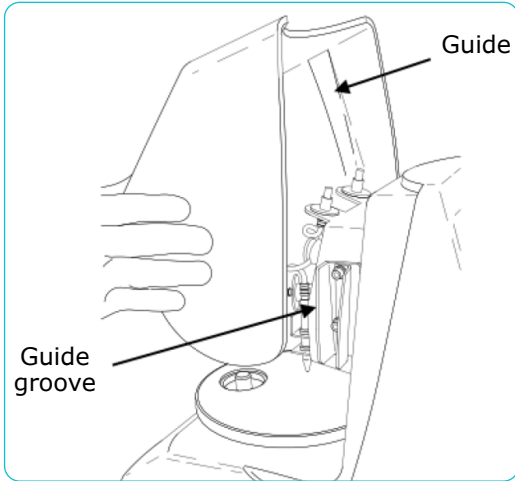

- Run a Decontamination cycle (see Decontamination function).
- Run a Cleaning cycle (see Cleaning function).
- Check the volume sprayed by the nebulizers (see Volume Verification function). Measure volumes three times for each nebulizer.
- For each nebulizer, compare each of the three values with the following tolerances:

- Autospraying function:  $25 \leq \text{Vol. } (\mu\text{L}) \leq 45$

If the three values measured fall within the above tolerances, the AutoSpray Station is ready for use.

If one or more of the values measured falls outside these tolerances, run a Volume Adjustment cycle (see Volume Adjustment function) to adjust the volumes.

## Replacing a nebulizer

Replace a broken or strongly clogged nebulizer with a replacement nebulizer (one spare nebulizer is provided in the box of accessories; see Spare Parts and Accessories). Carry out this operation in a controlled environment.

- Remove the protective cover by lifting it vertically. Wear gloves.

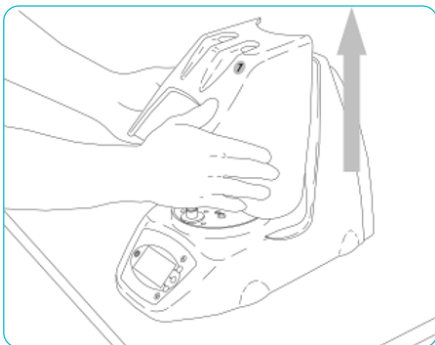

- Remove the broken or clogged nebulizer:

- Disconnect the nebulizer's air inlet tube from the Millex™-FG filter.

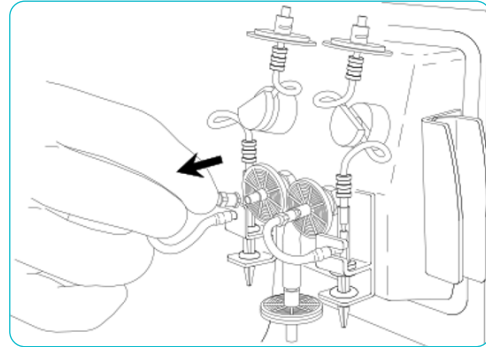

- Remove the nebulizer with its air inlet tube.

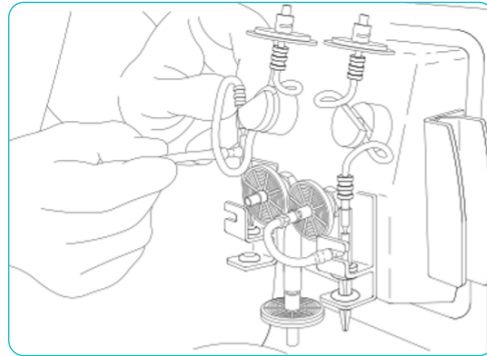

- Remove the silicone tube for liquids from the nebulizer inlet port.

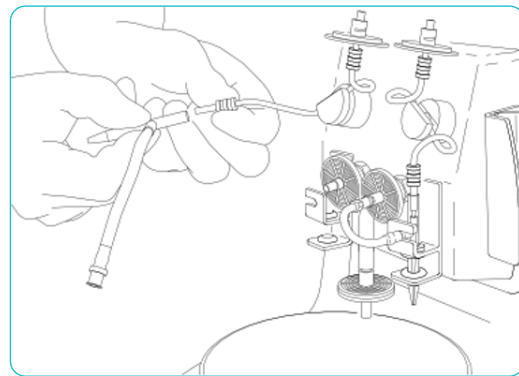

Replace the corresponding Millex™-FG filter (see Replacing the Silicone Liquid Tubes and Millex™ FG filters).

3. Install the spare nebulizer:

- a. Remove the protective cap from each end of the new nebulizer.

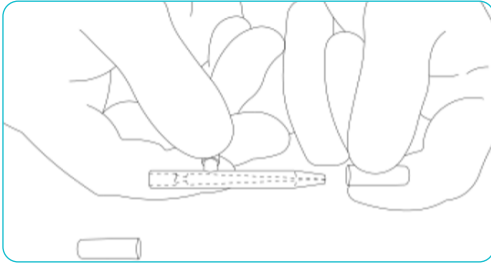

- b. Fit the spare nebulizer into the AutoSpray Station's nebulizer holder.

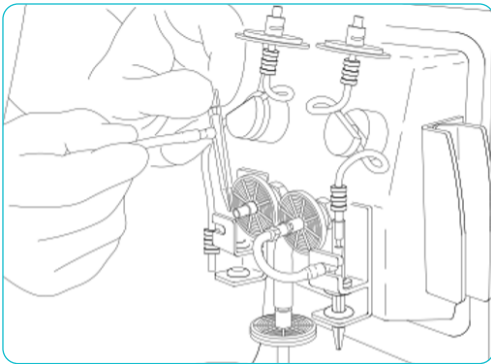

- c. Pivot the nebulizer to insert the air inlet into its dedicated slot of the nebulizer holder.

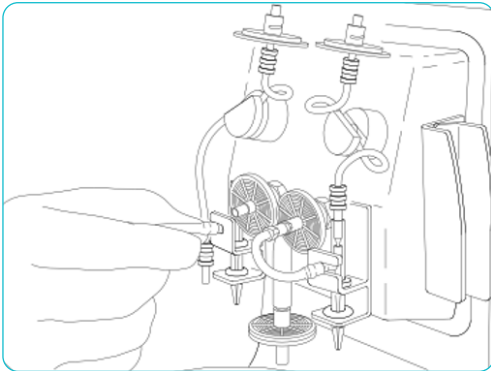

- d. Connect the nebulizer air inlet tube to the Millex™-FG filter.

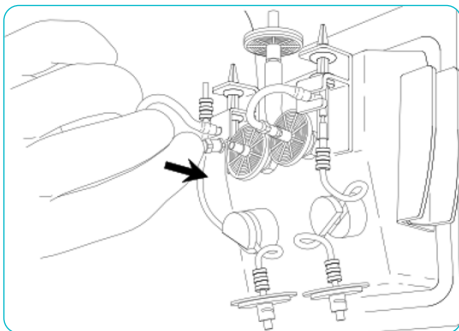

- e. Insert the lower end of the silicone tube for liquid as far as it will go into the nebulizer inlet port. The tube must form a loop between the pinch valve and the nebulizer inlet port. This section of the tube must not be kinked or pinched.

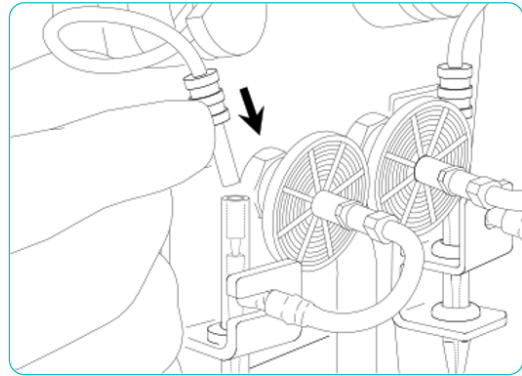

- 4. Fit the cover vertically, ensuring that the guides fit properly into the guide grooves.

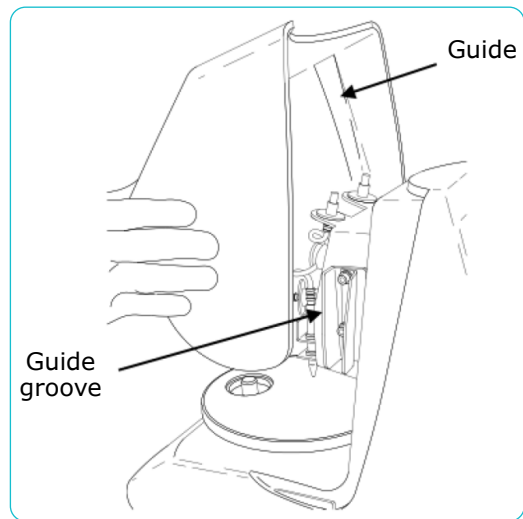

- 5. Run a Decontamination cycle (see Decontamination function).
- 6. Run a Cleaning cycle (see Cleaning function).
- 7. Run a Volume Adjustment cycle (see Volume Adjustment function) to set the volume sprayed by the newly installed nebulizer to within the right tolerances.

**Note:** It is critical to run a Volume Adjustment cycle when installing a new nebulizer, as each nebulizer has its own specific flow rate.

## Nebulizer maintenance

If the nebulizer is clogged use the nebulizer cleaner to remove any particles that may have entered the capillary tube or adhered to its outside.

Particle build-up in a nebulizer capillary or tip restricts the flow of liquid and reduces nebulizer efficiency and performance.

Carry out the following nebulizer maintenance steps in a controlled environment:

1. Remove the protective front cover by lifting it vertically. Wear gloves.

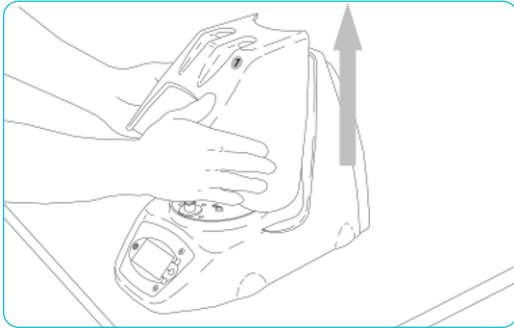

2. Disconnect the air inlet tube from the Millex™ FG filter

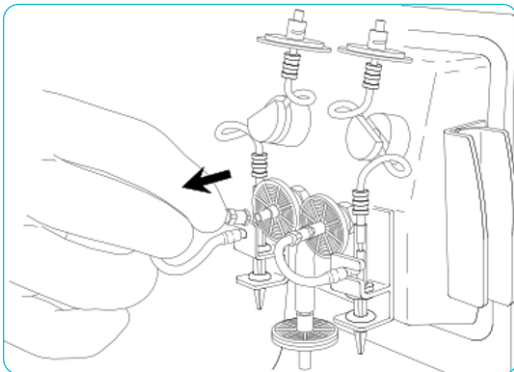

3. Remove the nebulizer, complete with its inlet tube for air.

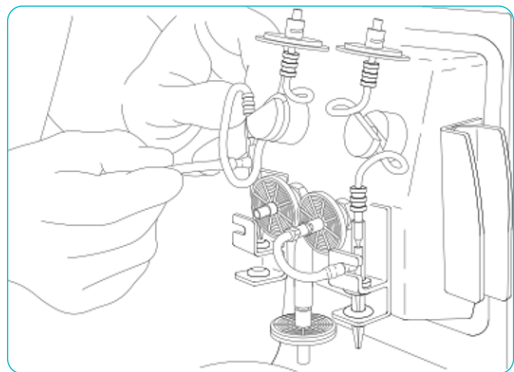

**Caution:** Identify and record the serial numbers of nebulizer 1 and nebulizer 2 so they can be mounted to their previous positions again after decontamination.

4. Remove the silicone tube from the nebulizer's inlet port for liquid.

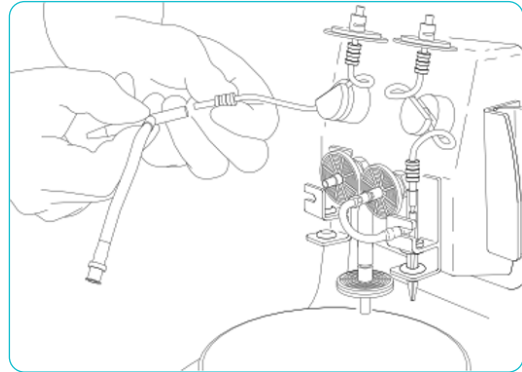

5. Remove the air tube from the nebulizer side arm by pulling it firmly.

**Note:** Leave the air tube inside the controlled environment.

6. Clean the nebulizer using the nebulizer cleaner (70-Eluo syringe) provided in the box of accessories:

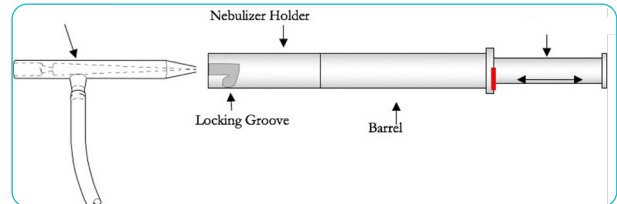

- a. Remove the nebulizer holder from the barrel by turning it anticlockwise.
- b. Entirely fill the barrel with hot sterilized Type 2 purified water (approx. 50 °C) by pulling the plunger outwards.

**Note:** We recommend using Type 2 water from a Milli-Q® water purification system

- c. Refit the nebulizer holder to the barrel by turning the holder clockwise until tight.
- d. Insert the nebulizer, tip first, into the nebulizer holder until the side arm lines up with the nebulizer locking groove. Press the nebulizer side arm into the locking groove to secure the nebulizer.
- e. With the end of the nebulizer directed towards a sink, press the plunger down in a single quick movement until it reaches the bottom of the barrel. Carefully hold the nebulizer in position and restrict flow through the nebulizer side arm by covering its opening with your thumb.
- f. Remove the nebulizer from the nebulizer holder.
- g. Leave the nebulizer filled with water for five minutes.
- h. Repeat steps "a" to "e".

- i. Push some air through the nebulizer by pulling and pushing the plunger three or four times to remove remaining water.
  - j. Remove the nebulizer from the nebulizer holder.
7. Refit the air tube onto the nebulizer's side arm, pushing it on firmly.
  8. Refit the nebulizer onto the AutoSpray Station nebulizer holder.

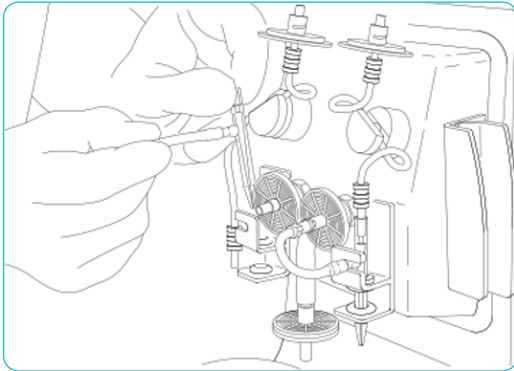

9. Pivot the nebulizer to insert the air inlet into its slot in the AutoSpray Station.

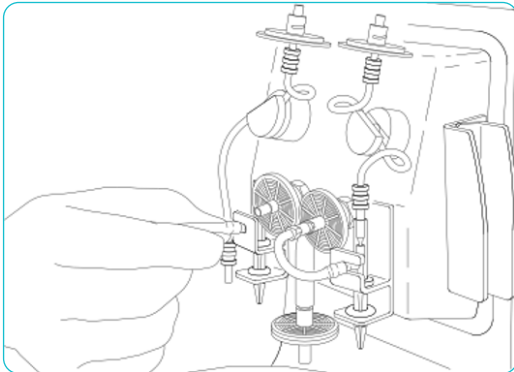

10. Connect the nebulizer air inlet tube to the Millex™-FG filter.

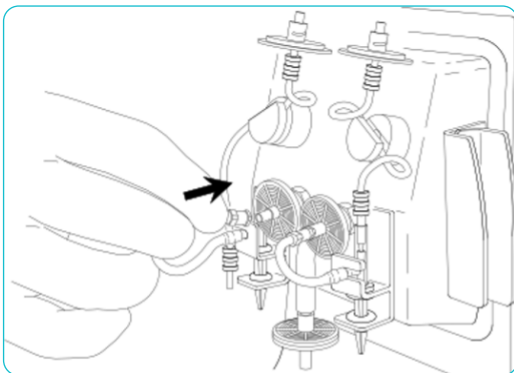

11. Insert the lower end of the silicone tube as far as it will go into the nebulizer inlet port. The tube must form a loop between the pinch valve and the nebulizer inlet port. This portion of the tube must not be kinked or pinched.

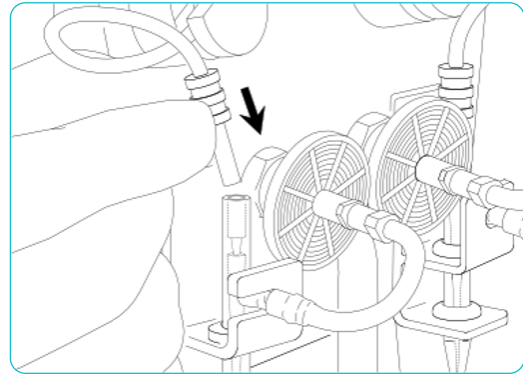

12. Fit the cover vertically, ensuring that the guides fit properly into the guide grooves.

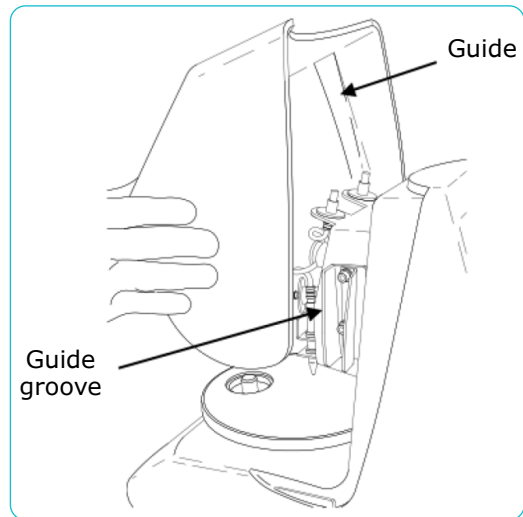

13. Run a Decontamination cycle (see Decontamination function).
14. Run a Cleaning cycle (see Cleaning function).
15. Check the volume sprayed by the nebulizers (see Volume Verification function). Measure the volumes three times for each nebulizer.
16. For each nebulizer, compare each of the three values with the following tolerances:
  - Autospraying function:  $25 \leq \text{Vol. } (\mu\text{L}) \leq 45$
 If the three values measured fall within the above tolerances, the AutoSpray Station is ready for use. If one or more of the values measured falls outside these tolerances, run a Volume Adjustment cycle (see Volume Adjustment function).

# Troubleshooting

If any of these problems persist, contact technical assistance (see Technical Assistance).

Problem	Possible Causes	Possible Causes and Corrective Actions
<b>The AutoSpray Station is powered up, but the screen does not light up, or the screen is difficult to read.</b>		Disconnect and reconnect the power unit from the power outlet. If the problem persists, the power unit may be faulty. Contact technical assistance.
		Adjust the display's brightness (see Adjusting Display Brightness).
<b>The Supply Fault screen is displayed and blinking.</b>	There was an electrical power disruption, and valves were opened.	If vials were loaded on the AutoSpray Station, clean the liquid that has dripped out of the nebulizers using a wipe soaked in 70% alcohol, then run a Cleaning cycle (see Cleaning function).
<b>Air bubbles are present in the fluid circuit.</b>		Ensure that the vial adapters are installed properly and that no air is leaking into the fluid path.
		Ensure that the silicone liquid tubing sits tight and that air is not leaking.
		Ensure that the Luer ports are not blocked.
		If the Luer ports are blocked, prime the corresponding nebulizer (see Priming function).
<b>Nebulizer is broken.</b>		Replace with the spare nebulizer provided in the box of accessories (see Replacing a Nebulizer).
<b>Reduced spray or no spray.</b>	The vial is empty.	Replace it with a new vial. If the new vial contains reagent, run a Priming cycle (see Priming function).
	The adapter is not correctly installed on the neck of the vial.	Press the vial adapter firmly into place. If the vial contains reagent, run a Priming cycle (see Priming function).
	The vial or its adapter is faulty.	Use a new vial and adapter. If the new vial contains reagent, run a Priming cycle (see Priming function).
	The liquid is not reaching the nebulizer.	Remove and re-install the vial onto the Luer port of the AutoSpray Station. If the vial contains reagent, run a Priming cycle (see Priming function).
	The section of silicone liquid tube inside the pinch valve is permanently pinched.	Replace tubing if it is damaged (see Replacing the Silicone Liquid Tubes and Millex™-FG Filters).
	The pinch valve does not open.	Remove the protective front cover and check if the pinch valve operates when spraying. If not, contact technical assistance.
	The air pump does not operate.	Ensure that the air is being pumped by removing the Millex™-FG filter and checking for air flow. If no air is being pumped, contact technical assistance.
	The air tubing is damaged.	Replace the air tubing.
	A Millex™-FG filter is clogged.	Replace the Millex™-FG filters (see Replacing the Silicone Liquid Tubes and Millex™-FG Filters).
A nebulizer is clogged.	This may occur if the cleaning procedure is not properly followed. Unclog the nebulizer (see Nebulizer maintenance). Use the 5 mL female Luer syringe provided in the box of accessories to unclog the nebulizer. Remove any vial installed in the AutoSpray Station. Fill the 5 mL female Luer syringe with filter-sterilized Type 2 purified water. Place the tip of the syringe into the AutoSpray Station's Luer port and force liquid into the fluid circuit by pressing the syringe plunger firmly while running a Priming cycle. If necessary, repeat this operation two or three times. Run a Decontamination cycle (see Decontamination function), a Cleaning cycle (see Cleaning function), and volume verification (see Volume Verification function) for the clogged nebulizer. If this does not solve the problem, use the nebulizer cleaner (70-Eluo syringe) to unblock the nebulizer. The nebulizer cleaner cleans the inside and outside of the nebulizer capillary tube (see Nebulizer Maintenance). If this does not solve the problem either, replace the nebulizer with the spare nebulizer from the box of accessories or a new one (see Replacing a Nebulizer and Spare Parts and Accessories).	

<b>Volume verification produces results that fall outside tolerance.</b>	Replace the nebulizer (see Replacing a Nebulizer and Spare Parts and Accessories).
	Run a Decontamination cycle (see Decontamination function), a Cleaning cycle (see Cleaning function), and then verify the volume (see Volume Verification function).
	Review troubleshooting section for reduced spraying or no spraying to solve such problems.
	Run a Volume Adjustment cycle (see Volume Adjustment function) to reset the volumes to within the right tolerances.
<b>The following warning is displayed during the volume adjustment cycle: Volume Adjustment Autospraying Nebulizer 1 (or 2)—ERROR Please contact Millipore.</b>	Review troubleshooting section for reduced spraying or no spraying to solve the problem.

## Spare Parts and Accessories

Description	Quantity per Pack	Catalogue Number
AutoSpray Station	1	MXRP2SPRKT
Milliflex <sup>®</sup> Oasis <sup>®</sup> Rapid Funnel, 0.45 µm membrane	24	MMHVMFX24
Milliflex <sup>®</sup> Rapid standard reagent kit	1	MXRPBLRST
Milliflex <sup>®</sup> Rapid cleaning and decontamination kit	20 cleaning +2 decontamination operations	MXRPCLKT1
Pad holder	1	MXRPSPFH1
Millex <sup>™</sup> -FG, 0.20 µm, hydrophobic PTFE, 25 mm, 0.2 µm	50	SLFGR25LS
Absorbent pads	100	AP1004700
PetriSlide <sup>™</sup> containers	100	PDMA04700
Nebulizer cleaner (70-Eluo syringe)	1	MXRPNEBCL
Glass nebulizer equipped with air tube	1	MXRPGGLASS
Silicone liquid tube	2	MXRPEZFIT
Stainless steel cap	2	MXRPCOVER
Milliflex <sup>®</sup> Rapid Power Supply—AU	1	MXRPWRSPAU
Milliflex <sup>®</sup> Rapid Power Supply—BR	1	MXRPWRSPBR
Milliflex <sup>®</sup> Rapid Power Supply—CN	1	MXRPWRSPCN
Milliflex <sup>®</sup> Rapid Power Supply—DK	1	MXRPWRSPDK
Milliflex <sup>®</sup> Rapid Power Supply—EU	1	MXRPWRSP EU
Milliflex <sup>®</sup> Rapid Power Supply—IN	1	MXRPWRSPIN
Milliflex <sup>®</sup> Rapid Power Supply—JP	1	MXRPWRSPJP
Milliflex <sup>®</sup> Rapid Power Supply—SZ	1	MXRPWRSPSZ
Milliflex <sup>®</sup> Rapid Power Supply—UK	1	MXRPWRSPUK
Milliflex <sup>®</sup> Rapid Power Supply—US	1	MXRPWRSPUS
Milliflex <sup>®</sup> Rapid Power Supply—ZA	1	MXRPWRSPZA
Milliflex <sup>®</sup> Rapid 2.0 FG turntable	1	MXRPPLAT1
Milliflex <sup>®</sup> Rapid 2.0 filter holder	1	MXRP2SPFH1
Milliflex <sup>®</sup> Rapid cover for vial holder	1	MXRPCOVER
Air tube	2	MXRPAIRTU

# Specifications and Operating Requirements

<b>Dimensions</b>	Width	210 mm
	Depth	400 mm
	Height	310 mm
	Weight	11 kg
<b>Materials of Construction</b>	Turntable	316 L stainless steel
	Pad holder	316 L stainless steel
	Membrane holder	316 L stainless steel
	Caps	316 L stainless steel
	Cover	Polyurethane
	Casing	Polyurethane
	Keypad	Polyester
	Pinch valve	Polyacetal and cold rolled steel, nickel plated
	Silicone liquid tube	Silicone rubber
	Tube coupling	PTFE
	Nebulizers	Borosilicate glass
	Silicone tube (air)	Silicone rubber
	Millex™-FG	25 mm PTFE membrane; polystyrene
	<b>Electrical Specifications</b>	Power supply input
Power supply output		24 VDC—2.5 A
Sprayer input (DC IN)		24 VDC
Sprayer power (DC IN)		25 W

# Operator & Equipment Safety Instructions

Please refer to the Operator & Equipment instructions addendum on [SigmaAldrich.com/milliflex-rapid-2](https://SigmaAldrich.com/milliflex-rapid-2)

## Standard Product Warranty

We make no warranties of any kind or nature, express or implied, including any implied warranty of merchantability or fitness for any particular purpose, with respect to any technical assistance or information that we provide. Any suggestions regarding use, selection, application or suitability of the products shall not be construed as an express or implied warranty unless specifically designated as such in a writing signed by an officer or other authorized representative of our company.

The applicable warranty for the products listed in this publication may be found at:

[SigmaAldrich.com/terms](https://SigmaAldrich.com/terms) (within the “Terms and Conditions of Sale” applicable to your purchase transaction).

## Technical Assistance

We recommend contacting Technical Assistance every 5,000 cycles or every 12 months to arrange for a full service of the AutoSpray Station.

### To receive technical assistance or place an order:

#### Customer Service numbers in the following countries:

France: 0825 045 645	Spain: 901 516 645 Option 1
Germany: 069 86798021	Switzerland: 0848 645 645
Italy: 848 845 645	United Kingdom: 0870 900 4645

For other countries across Europe, please call: +44 (0) 115 943 0840

Or visit: [SigmaAldrich.com/offices](https://SigmaAldrich.com/offices)

For Technical Service and more information visit: [SigmaAldrich.com/techservice](https://SigmaAldrich.com/techservice)

[SigmaAldrich.com](https://SigmaAldrich.com)

MilliporeSigma  
400 Summit Drive  
Burlington, MA 01803

