



NanoFabTx™ PLGA-micro, for synthesis of 10-30 µm particles

Protocol for Catalog No. [912212](#)

Introduction

NanoFabTx™ nanoformulation reagent kits enable users to encapsulate a wide variety of therapeutic drug molecules for targeted or extended drug delivery without the need for lengthy trial-and-error optimization. **NanoFabTx™** kits provide an easy-to-use toolkit for encapsulating a huge variety of therapeutics in nanoparticles, microparticles, or liposomes. The resulting particles are biocompatible and biodegradable and can be further modified to target specific tissues or to ensure slow and sustained drug release. Drug encapsulated particles synthesized with the **NanoFabTx™** kits are suitable for biomedical research applications such as oncology, immuno-oncology, gene delivery, and vaccine delivery.

The kits minimize laboratory setup with optimized protocols and step-by-step instructions for synthesizing drug-encapsulated microparticle-based formulations. A protocol for microfluidics-based synthesis using commercial platforms or syringe pumps is also included. The microfluidics protocol uses **NanoFabTx™** device kits, which provide all the microfluidics chips, fittings, and tubing required to get started with microfluidics-based synthesis (compatible microfluidics system or syringe pump required).

NanoFabTx™ PLGA-micro kit is designed for the synthesis of specifically sized, hydrophobic drug encapsulated poly(lactic-co-glycolic acid) (PLGA) microparticles. PLGA is a biocompatible and biodegradable polymer that has been widely used in drug delivery systems for controlled drug release of many different types of therapeutic molecules. The **NanoFabTx™ PLGA-micro** kit provides reagents and a protocol for microfluidic synthesis of 10 µm to 30 µm microparticles that enables users to identify the ideal microparticle size and drug loading for their research application.

Disclaimer

NanoFabTx™ PLGA-micro kit is for research use only; not suitable for human use. Please consult the Safety Data Sheet for information regarding hazards and safe handling practices.

Specifications

Storage	Store NanoFabTx™ PLGA-micro kits at 2-8°C. Protect from light.
Stability	Refer to the expiration date on the batch-specific Certificate of Analysis.

Materials

Materials supplied

Each **NanoFabTx™** PLGA-micro kit is supplied as follows:

Catalog Number	Quantity
907650	PLGA-Micro (500mg)
911631	Stabilizer-Micro (2 x 50ml)



Materials required, but not supplied

Catalog Number	Quantity
911879	NanoFabTx™ Microfluidic - micro, device kit for synthesis of 10-30µm particles
32222	Dichloromethane
276855	Dimethyl Sulfoxide (DMSO)
V7130	Glass scintillation vials (20 ml capacity)
SLFH025	Syringe filters 0.45µm (for filtering non-aqueous solutions like polymer, DCM, and DMSO)
SLHAR33SS	Syringe filters 0.45µm (for filtering aqueous solutions like stabilizer solution)
	Deionized water

Materials required for use with the Dolomite Microfluidics system, but not supplied

Catalog Number	Description
	Pressurized pump system (protocol requires two or three pumps) (e.g. Dolomite MitoS P-Pump). Further information for compatible Dolomite Microfluidic pumps and microfluidic systems can be found at https://www.dolomite-microfluidics.com/products/nanofabtx-hardware-solutions/ .
	Dolomite flow sensors (protocol requires two flow sensors). Further information for compatible Dolomite Microfluidic flow sensors https://www.dolomite-microfluidics.com/products/nanofabtx-hardware-solutions/ .

Materials required for use with syringe pumps, but not supplied

Catalog Number	Description
	Syringe pumps (protocol requires two or three pumps) (e.g. Harvard Apparatus – PHD Ultra pumps)
	Syringes compatible with syringe pumps required (recommended with Hamilton® GASTIGHT® syringes, Cat. No. 26211-U).

Before you start: Important tips for optimal results

Filter solutions. For best results, filter the PLGA solution through a 0.45 µm syringe filter (Cat. No. [SLFH025](#)) before use. In addition, filter the stabilizer solution through a 0.45-µm syringe filter (Cat. No. [SLHAR33SS](#)) before use.

Drug encapsulation. This protocol was developed in the absence of drug. The protocol can be adapted to synthesize drug-encapsulated microparticles by premixing the drug with the polymer solution. The solvent used must completely dissolve the drug of interest. Hydrophobic drugs can be especially difficult to dissolve and require careful attention. Hydrophobic solvents such as DMSO, or dichloroform DCM are appropriate, but DMSO is recommended because it can dissolve a high concentration of the drug and is compatible with the solvents used to dissolve the PLGA polymer. We recommend that you create a concentrated stock solution of your drug using compatible solvents to facilitate dilutions in the polymer solutions during synthesis.

Volume of collected nanoparticles. The volume of microparticle suspension can be controlled by adjusting the running/collection time.

Reduce blockages with proper cleaning. Always clean the microfluidics system after the synthesis of each batch of microparticles. Insufficient cleaning can result in blockages in the microfluidics chip and tubing. A well-maintained microfluidics chip can be used multiple times if cleaned and stored properly.



Prime the tubing and chip. Prime the tubing and the microfluidics chip before starting microparticle synthesis. Priming purges gases from the fluid pathways, conditions the chip surface with the stabilizers, and serves as a check of chemical compatibility for all wetted parts of the system. In addition, priming reduces or prevents precipitation of reagents inside the system in the case of backflow, jetting, or chaotic mixing. Precipitation of reagents can irreversibly block the microfluidics chip.

Flow rate calibration. When using pressurized pumps with flow sensors, it is important to note that the flow rates displayed on the flow sensor are not calibrated for organic solvents. A calibration curve must be created for other solvents, like dichloromethane, to calculate the corrected flow rate. To synthesize PLGA microparticles with this protocol with following equation was used to calculate corrected flow rates for syringe pumps listed in Table 1. For your reference, the following equation can be used to calculate corrected flow rates for syringe pumps.

- For PLGA 0 to 25% weight concentration: Corrected Flow Rate = 0.8158*(Pressurized Pump Set Flow Rate)^{1.6282}
- For PLGA 3 to 7.5% weight concentration: Corrected Flow Rate = 0.903*(Pressurized Pump Set Flow Rate)^{1.542}

Using syringe pumps: The flow rates listed in the protocol are optimized using pressurized pumps with flow sensors attached and syringe pumps. If a different brand of pressurized pump or syringe pump is used, the size of the microparticles may slightly deviate from the protocol.

When using syringe pumps, gradually increase flow rate in a stepwise fashion to the desired flow rate. Ensure valves are open in the flow path since back pressure can build up and cause leaks.

Procedure – Microfluidic synthesis of PLGA microparticles

The **microfluidics-based method** can be used to synthesize microparticles with a narrow size distribution, enhanced control over each stage of particle fabrication, greater particle yields, ease of scalability, and excellent reproducibility compared to traditional synthesis techniques. Microparticles between 10 - 30 µm can be synthesized following the recommended PLGA concentration and flow rates in **Table 1**. This microfluidics protocol is for use with a Dolomite Microfluidics system (**Figure 1**) or syringe pumps (**Figure 2**). Under most conditions, microfluidics pumps can yield improved reproducibility compared to the use of syringe pumps.

Table 1: Microparticle size based on PLGA concentration and flow rates

Selected final microparticle size (µm)	PLGA concentration (w/w)	Stabilizer Flow Rate* (µl/min)	Pressurized Pump PLGA Flow Rate (µl/min)	Syringe Pump Corrected PLGA Flow Rate (µl/min)	Droplet size before solvent removal (µm)
7.5	0.5%	120	0.82	1	34.51
9	1.0%	110	0.82	1	35.34
13.4	2.5%	90	0.82	1	26
14	3.5%	130	0.90	1	26.7
18	5.0%	130	0.90	1	28.59
22	7.5%	120	0.90	1	31.41
22.5	6.0%	130	0.90	1	33.78
26	0.5%	20	24.10	8	102.47
26.56	1.0%	20	29.19	9	100.44
33.5	2.5%	30	40.47	10	105.97
35.1	3.5%	25	26.74	9	98.43
37.13	7.5%	25	18.15	7	79.45
37.41	5.0%	30	22.30	8	87.71
39.2	6.0%	25	18.15	7	85.11

Note: Table recommendations for PLGA concentration and flow rates are based on blank microparticles, incorporation of drug may slightly change microparticle size. *The stabilizer flow rate is ideal for either pressurized or syringe pumps.

A. Set up the microfluidics system

This microfluidics protocol is designed for use with the corresponding NanoFabTx™ Microfluidic - micro device kit (Cat. No. [911879](#)) which contains all required device components for synthesizing microparticles and a detailed protocol for use with a Dolomite Microfluidics system or syringe pumps. Please follow the protocol with NanoFabTx™ Microfluidic - micro device kit (Cat. No. [911879](#)) to set up the microfluidics system.

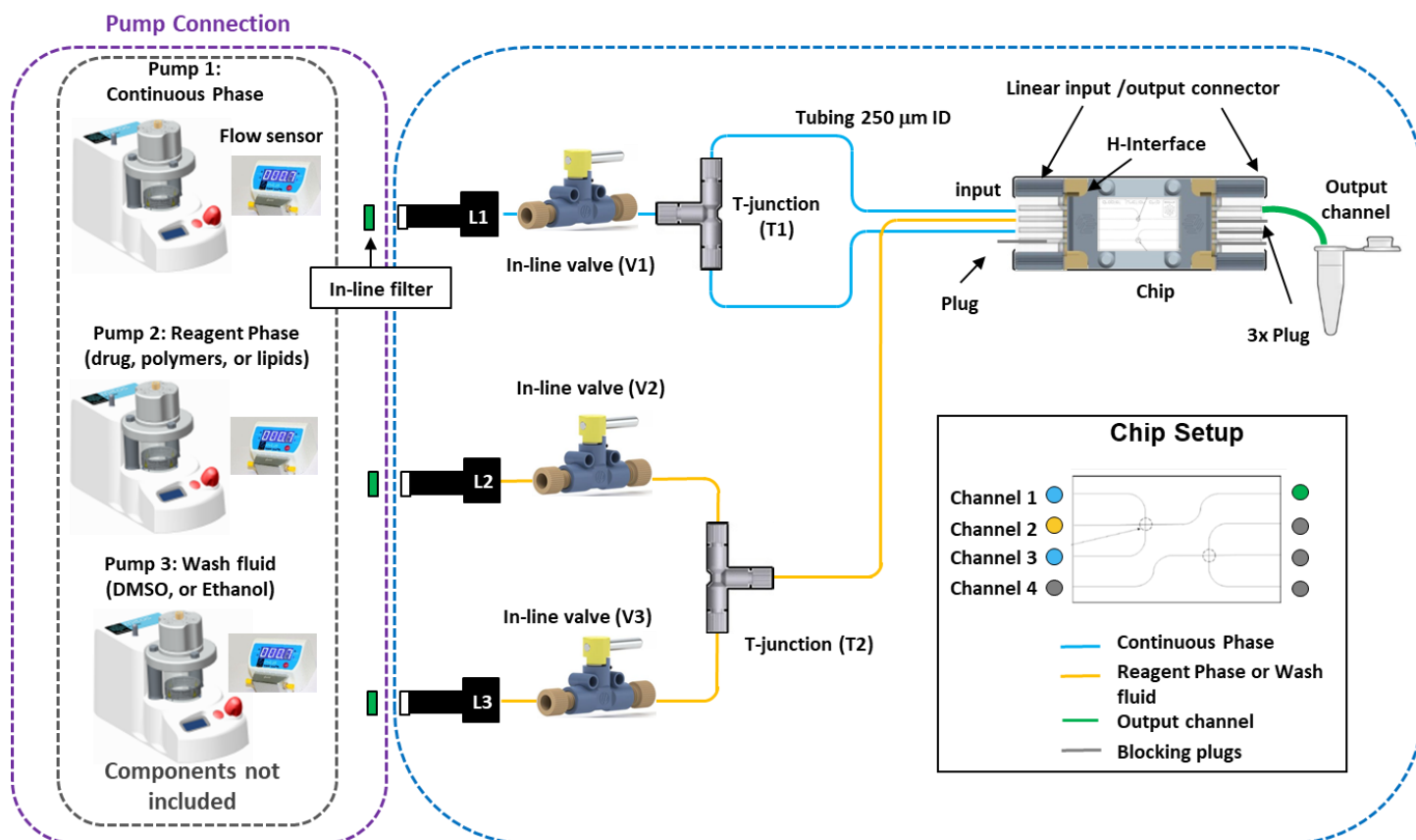

Figure 1: Schematic of the microfluidics setup for the Dolomite Microfluidics system. The manifold is supplied preassembled. The microfluidics chip is packaged separately. In-line filters are supplied for connection to microfluidic pumps.

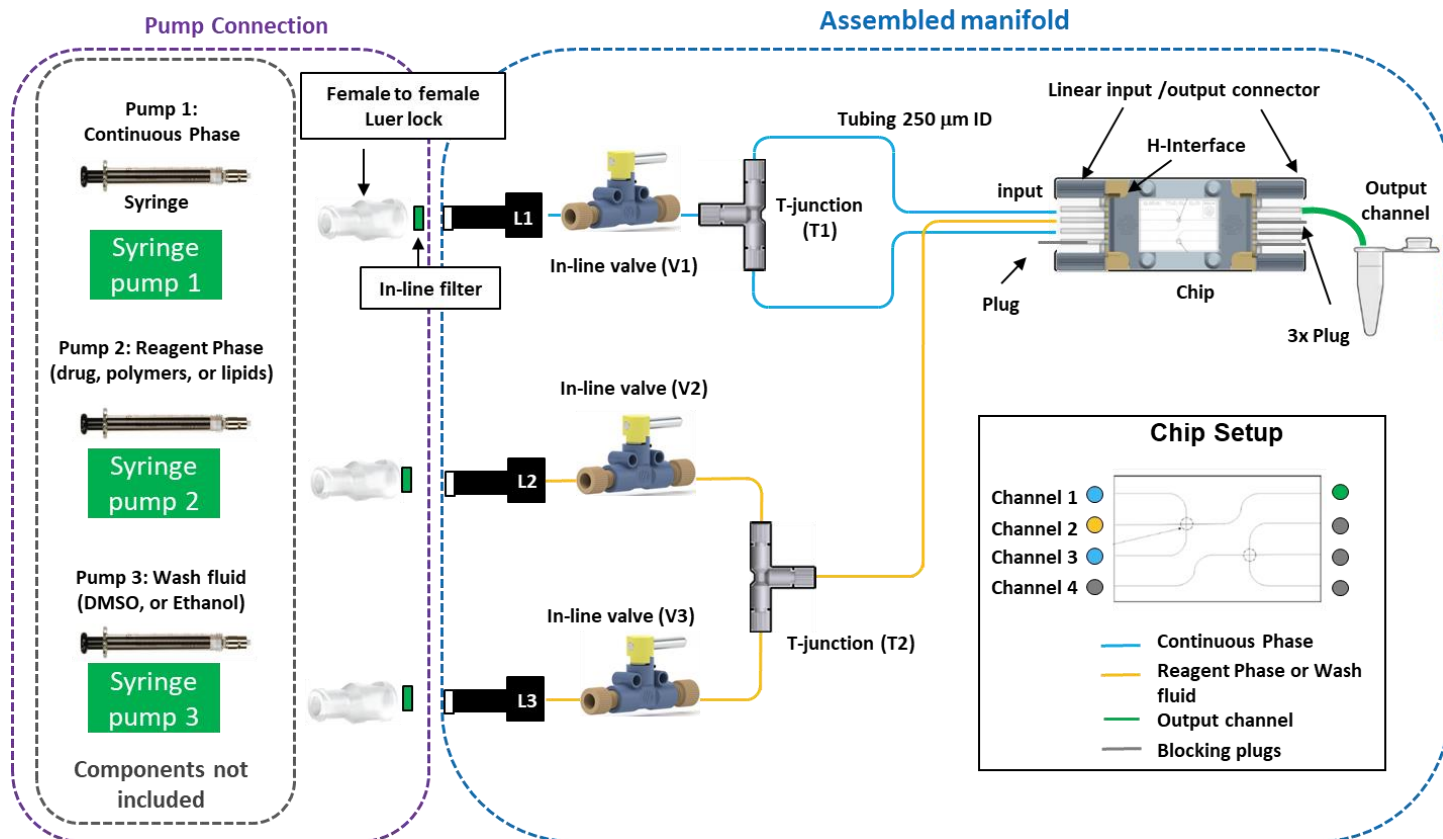

Figure 2: Schematic of the microfluidics setup for syringe pumps. The manifold is supplied preassembled. The microfluidics chip is packaged separately. In-line filters and luer locks are supplied for connection to syringe pumps.

B. Prepare reagents

1. Prepare 5 ml of PLGA stock solution

- After selecting desired microparticle size from **Table 1**, prepare 5 ml of PLGA solution in a glass vial (Cat. No. [V7130](#)) by mixing the indicated amounts of PLGA-Micro and DCM from **Table 2**.

Note: For encapsulating hydrophobic drugs in the microparticles, dissolve the polymer in a small volume of DCM, add an appropriate amount of your drug solution and adjust the polymer/drug solution volume to 5ml by adding DCM as needed.

- Cap the vial and vortex solution gently for 1-2 mins to completely dissolve the polymer. The final solution should be a clear transparent solution. DO NOT vortex or shake vigorously.
- Filter the PLGA stock solution through a 0.45-µm syringe filter (Cat. No. [SLFH025](#)) before use.

Table 2: Preparation of PLGA polymer stock solution

Final PLGA stock solution concentration (% w/w)	PLGA mass (mg)	Approximate volume of DCM (ml)
0.5	33.25	5
1	66.5	5
2.5	166.25	5
5	332.5	5
7.5	498.75	5



- Add DCM to the vial to achieve a total mass of 6.65 gm using a pipette, approximately 5 ml, and cap securely.
2. Prepare 10 ml of stabilizer solution
 - Filter 10 ml of Stabilizer-Micro included in the kit with a 0.45 µm syringe filter (Cat. No. [SLHAR33SS](#)) into a 20 ml glass vial (Cat. No. [V7130](#))
 3. Prepare 5 ml of stabilizer solution for sample collection
 - Filter 5 ml of Stabilizer-Micro included in the kit with a 0.45 µm syringe filter (Cat. No. [SLHAR33SS](#)) into a 20 ml glass vial (Cat. No. [V7130](#))

C. **Synthesize microparticles**

1. Assemble microfluidics system
 - i. Assemble the microfluidics system as described in protocol with *NanoFabTx™ Microfluidic - micro* device kit (Cat. No. [911879](#))

Note: *The synthesis of microparticles using the Dolomite Microfluidics system or syringe pump can be carried out in either a three-pumps (as shown in **Figure 1** and **Figure 2**) or two-pumps configuration (pump 1 and 2 only). In the three-pumps configuration, a vial of priming solution is kept in pump 3 throughout the process. Pump 3 can be used for the washing step without the need for swapping the vials in pump 2 when using a two-pumps configuration. For washing, simply close valve V1 and V2 and open valve V3 and start the flow of solvent using the pump software.*

2. Insert priming solvent DMSO into microfluidics system
 - Place a clean vial (Cat. No. [V7130](#)) containing 10 ml of DMSO (filtered using a 0.45 µm syringe filter, Cat. No. [SLFH025](#)) inside pump 1. Pump 1 is connected to channels 1 and 3 of the microfluidics chip via T-junction (T1). (see **Figure 1** and **Figure 2**)
 - Place another vial (Cat. No. [V7130](#)) of 10 ml DMSO (filtered using a 0.45 µm syringe filter, Cat. No. [SLFH025](#)) inside pump 2 and pump 3. Pump 2 and pump 3 are connected to channel 2 of the microfluidics chip via T-junction (T2).
 - Keep valves V1, V2, and V3 closed. They connect to pump 1, pump 2 and pump 3 respectively.
2. Prime the system
 - Place a waste collection vial at the output channel to collect waste generated during setup and priming.
 - Open valve V2 to flush the assembled manifold with the DMSO (no PLGA or drug) by setting a flow rate of 100 µl/min for pump 2 using the Flow Control Center software for the Dolomite microfluidics



system or using the syringe pump interface. Keep valve V3 closed if using the two-pumps configuration.

Note: When using syringe pumps, gradually increase flow rate in a stepwise fashion to the desired flow rate. Ensure valves are open in the flow path since back pressure can build up and cause leaks.

- Close valve V2 and open valve V1 to flush the assembled manifold with DMSO by setting a flow rate of 100 $\mu\text{l}/\text{min}$ for pump 1. For further details on priming the system refer to the device kit protocol (Cat. No. [911879](#))

3. Prepare microparticles

- From **Table 1**, select the desired size of microparticle you want to synthesize and follow the recommended PLGA concentrations, PLGA flow rate (based on your pump type), and stabilizer flow rate.
- Place a vial (Cat. No. [V7130](#)) containing 10 ml stabilizer solution inside pump 1 and the vial (Cat. No. [V7130](#)) of polymer solution inside pump 2 (refer to **Table 2** for preparation).
- Check that both valves V1, V2, and V3 are closed. Always keep valve V3 closed when using the two-pump configuration.
- Open valve V1 and set the flow rate for the stabilizer solution to the flow rates listed in **Table 1** for your desired particle size using the Flow Control Center software of the Dolomite microfluidics system or syringe pump interface.
- The flow rate of the stabilizer solution will stabilize within a few seconds.
- Set the flow rate for pump 2 of the polymer solution to the rate listed in Table 1 for your desired particle size using the Dolomite microfluidic system or syringe pump interface, and open valve V2.
- The flow rates of both solutions will stabilize within a few seconds. Optional: the fluid flow of the two solutions can be visualized by a high-speed microscope.
- After approximately 1 minute of flow, replace the waste collection vial with a sample collection vial containing 5 ml of stabilizer solution at the output channel and collect the microparticle suspension.

Note: To confirm microparticle synthesis, collect a small quantity of sample and place it on a glass slide under a light microscope. Spherical droplets will be visible and will have varied droplet sizes. Leave sample on the slide for 5-10mins to allow solvent evaporation. Larger droplets will appear in the center of the sample, where there is less solvent evaporation and smaller droplets will appear near the edges of the fluid sample due to faster solvent evaporation.

- When you have collected the desired volume of the microparticle suspension, transfer the output channel tubing to the waste collection vial, close valves V1 and V2, use the Flow Control Center software or syringe pump interface to stop fluid flow, and remove the solution vials from pump 1 and pump 2.
- Clean the microfluidics system after each use using the method below. Improper cleaning can result in chip and tubing blockages.

5. Solvent evaporation and microparticles purification

- The solvent can be removed from prepared microparticles by uncapping the vial and stirring the microparticles at a very low speed on a magnetic stirrer for 4-8 hours. Alternatively, for non-invasive



solvent removal, place the microparticle suspension on an uncovered Petri dish and allow the solvent to fully evaporate.

- Collect the microparticles by centrifugation of the microparticles suspension at 3000 rpm at room temperature.
- Wash the microparticles 3 times with DI water to remove the remaining stabilizer.

6. Measure the size of the microparticles

- Measure the size of the microparticles with a dynamic light scattering instrument and scanning electron microscopy (SEM).

D. Clean the microfluidics system

- Follow this cleaning procedure after each run to remove any remaining polymer precipitates or deposited stabilizer.
- Use DMSO to clean the tubing and microfluidics chip. DMSO is the preferred cleaning solvent because both the stabilizer and polymer have high solubility in DMSO.
- Filter 10 ml DMSO through a 0.45 μm syringe filter into each of two vials (Cat. No. [V7130](#)).
- Close valves V1, V2, and V3 and place a waste collection vial at the output channel tubing.
- Place the vials of filtered DMSO in pumps 1 and 2.
- Open valve V1 and set the flow rate of pump 1 to 100 $\mu\text{l}/\text{min}$.
- Set the flow rate of pump 2 to 100 $\mu\text{l}/\text{min}$ and immediately open valve V2.

Note: If using a three-pump configuration, washing is not required for pump 3.

- Gradually increase the flow rate on both pumps to 300 $\mu\text{l}/\text{min}$. Run the system for 3 minutes to completely remove any PLGA or stabilizer precipitated inside tubing or on the microfluidics chip.
- When the cleaning process is complete, close valves V1 and V2 and use the software or pump interface to immediately stop the flow of the liquids through pumps 1 and 2.
- Remove the DMSO vials.
- Disconnect the linear input/output connectors and remove the microfluidics chip from the H-interface.
- Ensure that the microfluidics chip is returned to its box for storage, or is placed in another clean, dust-free environment.

Troubleshooting

Detailed troubleshooting on the microfluidics setup is provided in the troubleshooting guide included in the *NanoFabTx™ Microfluidic - micro, device kit* (Cat. No. [911879](#)). Due to the numerous connections between microfluidics components, and the narrow flow paths for the fluids, you may encounter leaks or blockages. This section presents information on and potential solutions for commonly encountered problems.

1. Microparticles are not in the defined size range

Possible cause – This protocol is optimized for synthesis of PLGA microparticles in the size range as described in **Table 1**. If you encapsulate a drug in the PLGA microparticles, the size of your microparticles may vary from the size range reported here.



Solution – You can tune the size of microparticles by varying the concentrations of PLGA polymer. In general, increasing the PLGA concentration yields larger microparticles. Further, you can tune the size of microparticles by changing flow rates when using the microfluidics-based method.

Possible cause – This procedure is optimized for the Dolomite microfluidic system or the recommended syringe pumps. The flow rates listed in the protocol are optimized using pressurized pumps with flow sensors attached. If you use different flow rates or alternative syringe pumps, the size of your microparticles may vary from the size range reported here.

Solution – If syringe pumps are used instead of pressurized pumps from Dolomite, use the recommended flow rates for the syringe pumps in **Table 1**.

2. Polydisperse microparticles

PDI is the standard deviation of the particle diameter distribution divided by the mean particle diameter. PDI is used to estimate the average uniformity of a particle solution; higher PDI values correspond to a greater size distribution in the microparticle sample. A sample is considered monodisperse when the PDI value is less than 0.1

Possible cause – In the microfluidics method, polydisperse samples can occur if the flow in the tubing or microfluidics chip is uneven or blocked.

Solution – The next sections provide tips to minimize uneven flow or remove blockages

3. Uneven flow

Possible cause – Uneven flow can be caused by bubbles of air in the system.

Solution – Allow fluid to flow through the system for 1–2 minutes to clear bubbles. You can usually see the bubbles passing through the microfluidic chip. If this approach does not remove the bubbles, sonicate the solutions for 30 min and vent the pressure chamber.

Possible cause – If the flow becomes unstable when the microfluidic system has been in operation for a while, one of your fluid bottles may have run dry or the pick-up tubing might not reach the bottom of a vial.

Solution – Check that the vials contain enough reagent and that the 250- μ m pick-up tubing is long enough to collect from the bottom of each vial.

Possible cause – If none of the above solutions leads to even flow, restart the syringe pump or software system.

Solution – Stop all flow, close and reopen the Flow Control Centre software, and restart the flow. If this method does not solve the problem, the system may have a blockage. Check for blockages as detailed in the next section.

Possible cause – If the system has no blockages, the flow sensor may not function correctly.

Solution – Replace the flow sensor.

4. Leak in system

Possible cause – Changes/fluctuations in system pressure or flow rate can arise from a leak in the system.

Solution – Before troubleshooting a possible blockage, make sure that all connectors are properly fitted and that the system has no apparent leaks.



5. Blockage of tubing or microfluidics chip

Possible cause – During the synthesis of microparticles using the microfluidics setup, the introduction of dust fibers, deposition of precipitated polymers or stabilizer, drying of reagents inside the microfluidic chip or tubing, or improper cleaning procedures can cause blockage in the microfluidics chip or tubing.

Several indications suggest that a partial or complete blockage has occurred:

- Consistent flow rate is maintained when a pump is in flow control mode, but the pressure increases.
- Consistent pressure is maintained when a pump is in pressure control mode, but the flow rate decreases.
- The instrument software has set changes to the flow rate, but apparent flow rate does not change.
- The flow is significantly slower than expected.
- The flow rate fluctuates unexpectedly and affects droplet stability.

If a partial or transitory blockage is present, the pressure may increase gradually, then suddenly drop as the blockage moves along the flow path, and then increase again when the obstruction becomes lodged.

Solution – Blockages can occur anywhere in the flow path of the system; identifying the location of a blockage is a process of elimination

Start with the microfluidics chip, because sometimes blockages (dust or hair) are visible under a microscope. If you find a blockage on the chip, monitor it while you vary the pump pressure to try to dislodge it. If a blockage on the chip cannot be cleared, the chip will need to be replaced.

If you see no physical blockage in the microfluidics chip, disconnect the chip interface and check whether liquid flows from the tubing. If liquid now flows from the disconnected tubing the blockage is likely either in the chip or the connector was improperly seated against the chip. If the system has a T-junction connector that splits the flow of a solution into two inputs, check that the flow rates through each input are identical. If the flow is asymmetric, a blockage could be somewhere between the T-junction connector and the chip. First replace the tubing and see if this fixes the problem; if not, replace the T-junction connector.

If it is not already apparent which line is blocked, vary the flow rate of the solutions one at a time while observing the ends of the tubing. This step will help to identify which line is blocked.

Work your way back through the system, from the chip to the pump, one component at a time, and check for stable flow at each stage. When you find the section that contains the blockage, simply replace it.

The blockage may have occurred because of particulate contamination in your solution(s). Refilter solutions through a 0.45µm syringe filter before use.